

 **resto italia**[®]
CATERING EQUIPMENT MANUFACTURERS

dal 1961...

**resto italia's products
support professionals
with their Italian quality**





Forni / Ovens

Forni Elettrici / Electric Ovens	10
Piccoli Forni Elettrici / Small Electric Ovens	32
Forni a Gas / Gas Ovens	36
Accessori Pizza Line / Accessories Pizza Line	40

Preparazione Impasto / Kneading Preparation

Impastatrici a Spirale / Spiral Mixers	46
Impastatrici a Forcella / Fork Kneading Machines	62
Impastatrici Planetarie / Rotary Kneaders	64

Lavorazione Impasto / Kneading Processing

Spezzatrici e Arrotondatrici / Dividers and Rounding Machines	70
Formatrici / Shaping Machines	74
Dilaminatrici / Pizza Dough Rollers	76

Taglio / Cutting

Tagliaverdure / Vegetable Cutters	80
---	----

Preparazione Carne / Meat Preparation

Affettatrici / Slicers	88
------------------------------	----

Cottura / Cooking

Piastre Elettriche / Electrical Grills	96
Tostiere / Toasters	102
Griglie a Pietra Lavica / Lava Stone Grills	104
Fry Top Elettrici e a Gas / Electric and Gas Fry Tops	106
Crepiere / Pancakes Makers	108
Friggitrici Elettriche / Electrical Fryers	110

Refrigerazione / Refrigeration

Armadi Refrigerati Ventilati / Refrigerated Ventilated Cabinets	116
Banchi Pizza Refrigerati Ventilati / Refrigerated Ventilated Pizza Counters	118
Vetrinette Refrigerate / Refrigerated Topping Units	120
Banchi Refrigerati Ventilati / Refrigerated Ventilated Counters	122
Abbattitori di temperatura / Blast Chillers	124



Forni Ovens

TS LINE

Forno elettrico modulare ideale per pizza al piatto per alti volumi di lavoro

Modular electric oven ideal for round pizza and high volumes of work





Quadro comandi digitale / Digital control panel



Valvola regolazione umidità / Humidity regulation valve



Sportello panoramico / Panoramic door



Cappa con motore elettrico di serie / Hood with electric motor as standard

Caratteristiche

- Forno con telaio e facciata in acciaio INOX per una maggiore solidità e durata nel tempo
- Da 4 a 18 pizze diam. 36Cm \varnothing - Da 1 a 6 teglie
- Pannello di controllo touch screen 5 pollici a colori
- Accensione programmabile
- 2 timer di cottura
- Funzione Eco
- Funzione Power Boost
- Gestione del calore da cima e della platea con percentuale, per una maggiore precisione e risparmio energetico
- Valvola di regolazione umidità
- Sportello ad apertura controllata (sistema a molle certificato), vetro ceramico ad alto isolamento termico.
- Guarnizione sigillante per migliore isolamento termico della camera di cottura.
- Maggiore efficienza e attenzione all'ambiente: coibentazione in "ecoblanc", riciclabile ed ecocompatibile, oltre a garantire un altissimo risparmio energetico, assicura zero dispersione, durante la manutenzione, rispetto alla lana di roccia
- Piano refrattario di serie sostituibile con piano in lamiera bugnata (su richiesta)
- 4.0 Ready. Forno predisposto per Industria 4.0

Features

- Oven with front and structural frame in stainless steel that makes it more solid and long-lasting
- From 4 to 18 pizza diam. 36Cm \varnothing - From 1 to 6 trays
- 5-inch color touch screen control panel
- Programmable starting
- 2 cooking timers
- Eco function
- Power Boost function
- Percentage regulation of the heat intensity on the top and the base, for a higher precision and energy saving
- Humidity regulation valve
- Door equipped with certified soft opening spring system, high insulation ceramic glass to have a more uniform cooking temperature.
- Additional insulating seal on the chamber frame, with internal spiral spring for thickness return.
- Higher energy efficiency and attention to the environment: insulation system "ecoblanc", reducing the decay of the mineral wool.
- Replaceable standard refractory top with embossed plate top (on request)
- 4.0 Ready. Oven suitable for Industry 4.0



TS LINE

	4	6	6 L	9
DIMENSIONI INTERNE cm INSIDE DIMENSIONS cm	72 72 14	72 108 14	108 72 14	108 108 14
DIMENSIONI ESTERNE cm OUTSIDE DIMENSIONS cm	113 98,5 41	113 140 41	154 98,5 41	154 150 41
DIMENSIONI IMBALLO cm PACKAGE DIMENSIONS cm	120 120 57	120 160 57	160 120 57	160 160 57
CAMERA COTTURA n° BAKING CHAMBER n°	1	1	1	1
POTENZA KW POWER KW	6.0	9.0	9.2	13.8
VOLT	230/400	400	230/400	400
TEMPERATURA °C TEMPERATURE °C	50/500°	50/500°	50/500°	50/500°
PESO Kg WEIGHT Kg	84	107	108	135
TOTALE PIZZE Ø 36 cm TOTAL PIZZA Ø 36 cm				
TEGLIE 60X40 cm PANS 60X40 cm	1	2	2	4
COD.	7021621004	7021621006	7021621006L	7021621009

OPTIONAL PIETRA REFRATTARIA CIELO
OPTIONAL TOP REFRACTORY STONE



PIANO IN LAMIERA BUGNATA IDEALE PER COTTURA IN TEGLIE
(IN ALTERNATIVA ALLA PIETRA REFRATTARIA PLATEA)
BUCKLED PLATE IDEAL FOR COOKING IN PANS
(AS AN ALTERNATIVE TO THE BOTTOM REFRACTORY STONE)

	DIMENSIONI cm DIMENSIONS cm	IMBALLO CM PACKAGE CM	PESO KG WEIGHT KG	OPTIONAL OPTIONAL	CODICE CODE
--	--------------------------------	--------------------------	----------------------	----------------------	----------------

CAPPA INOX FORNO CON MOTORE ELETTRICO DI SERIE - OVENS INOX HOOD WITH ELECTRIC MOTOR AS STANDARD

	4	114 128 38	119 133 41	21,00	✓	7020120013
	6	114 173 38	119 175 41	25,00	✓	7020120014
	6L	155 128 38	160 133 41	26,00	✓	7020120015
	9	155 169 38	160 174 41	29,00	✓	7020120016

CAPPA INOX FORNO A CONDENSAZIONE - OVENS INOX CONDENSATE EXHAUST HOOD

	4	113 139 43	140 120 90	104,00	✓	7020120213
	6	113 180 43	190 120 90	117,00	✓	7020120214
	6L	154 139 43	140 160 90	119,00	✓	7020120215
	9	154 180 43	190 160 90	131,00	✓	7020120216

SUPPORTO REGOLABILE - ADJUSTABLE SUPPORT

	4 / 4+4	114 99 85/90/95	120 30 20	27,00	/	7020100016
	6 / 6+6	114 140 85/90/95	145 30 20	30,00	/	7020100017
	6L / 6L+6L	155 99 85/90/95	160 30 20	30,00	/	7020100018
	9 / 9+9	155 140 85/90/95	160 30 20	32,00	/	7020100022

KIT PORTA TEGLIE - TRAYHOLDER KIT

	4 / 4+4	/	105 30 20	6,50	/	7020110014
	6 / 6+6	/	150 30 20	7,50	/	7020110015
	6L / 6L+6L	/	105 30 20	12,00	/	7020110016

SUPPORTO REGOLABILE - ADJUSTABLE SUPPORT

	4+4+4	114 99 55/60/65	120 30 20	23,50	/	7020100019
	6+6+6	114 140 55/60/65	145 30 20	26,50	/	7020100020
	6L+6L+6L	155 99 55/60/65	160 30 20	26,50	/	7020100021
	9+9+9	155 140 55/60/65	160 30 20	28,50	/	7020100023

KIT PORTA TEGLIE - TRAYHOLDER KIT

	4+4+4	/	105 30 30	5,00	/	7020110022
	6+6+6	/	150 30 30	6,50	/	7020110023
	6L+6L+6L	/	105 30 30	10,00	/	7020110024

COPPIA ANGOLARI - CORNERS COUPLE

	4 / 4+4 - 6L / 6L+6L	/	90 10 10	1,30	/	7020110017
	6 / 6+6 - 6+6+6	/	90 10 10	1,80	/	7020110018
	KIT RUOTE - CASTORS KIT	+ 14 cm	30 20 20	5,00	/	7020110019

TR LINE

Forno elettrico multifunzione modulare ideale per pizza in teglia, pasticceria e piccola panificazione
Disponibile in versione digitale ed elettromeccanica

Multifunction modular electric oven ideal for tray pizza, pastry and small bakery.
Available in both digital and electromechanical version





Pannello di controllo digitale / Digital control panel



Pannello di controllo elettromeccanico / Electromechanical control panel



Valvola di regolazione umidità / Humidity regulation valve



Piano in lamiera bugnata opzionale / Buckled plate as optional

Caratteristiche TR D (digitale)

- Disponibile altezza camera 18 (consigliata per pizzeria) o 27cm (per panificazione e pasticceria)
- Da 2 a 8 teglie
- Da 4 a 12 pizze diam. 40Cm ø
- Valvola di regolazione umidità
- Gestione del calore del cielo e della platea con percentuale, per una maggiore precisione e risparmio energetico
- Funzione Power Boost
- Timer di cottura
- Doppio strato di coibentazione in "ecoblanc"
- Posizionabile su celle di lievitazione di nostra produzione (temp. Max 70°)
- Maggiore efficienza e attenzione all'ambiente: coibentazione in "ecoblanc", riciclabile ed ecocompatibile, oltre a garantire un altissimo risparmio energetico, assicura zero dispersione, durante la manutenzione, rispetto alla lana di roccia
- Piano refrattario di serie sostituibile con piano in lamiera bugnata (su richiesta)
- Vaporiera (disponibile solo per TR a camera singola)

Features TR D (digital)

- Available with chamber h. 18 (Suggested for pizza) or h. 27Cm (ideal for bakery and pastry)
- From 2 to 8 trays
- From 4 to 12 pizza diam. 40Cm ø
- Humidity regulation valve
- Percentage regulation of the heat intensity on the top and the base, for a higher precision and energy saving
- Power Boost Function
- Cooking timer
- Double insulation layer in "ecoblanc"
- It can be placed on proving chambers of our production (max temp. 70°)
- Higher energy efficiency and attention to the environment: insulation system "ecoblanc", eliminating the decay of the mineral wool.
- Replaceable standard refractory top with embossed plate top (on request)
- Steamer (available only for single chamber TR)

Caratteristiche TR (elettromeccanico)

- Disponibile altezza camera 18 (consigliata per pizzeria) o 27cm (per panificazione e pasticceria)
- Da 2 a 8 teglie
- Da 4 a 12 pizze diam. 40Cm ø
- Valvola di regolazione umidità
- Termostati comandati da scheda relè
- Gestione separata della potenza di cielo e platea
- Accensione separata resistenze cielo e platea
- Doppio strato di coibentazione in "ecoblanc"
- Posizionabile su celle di lievitazione di nostra produzione (temp. Max 70°)
- Maggiore efficienza e attenzione all'ambiente: coibentazione in "ecoblanc", riciclabile ed ecocompatibile, oltre a garantire un altissimo risparmio energetico, assicura zero dispersione, durante la manutenzione, rispetto alla lana di roccia
- Piano refrattario di serie sostituibile con piano in lamiera bugnata (su richiesta)

Features TR (electromechanical)

- Available with chamber h. 18 (Suggested for pizza) or h. 27Cm (ideal for bakery and pastry)
- From 2 to 8 trays
- From 4 to 12 pizza diam. 40Cm ø
- Humidity regulation valve
- Thermostats controlled by a relay card
- Base and top heating elements activated by separate switches
- Regulation of the heat intensity on the top and the base
- Double insulation layer in "ecoblanc"
- It can be placed on proving chambers of our production (max temp. 70°)
- Higher energy efficiency and attention to the environment: insulation system "ecoblanc", eliminating the decay of the mineral wool.
- Replaceable standard refractory top with embossed plate top (on request)

Funzionamento vaporiera

Accendere l'apparecchio con l'interruttore posto a lato del display di controllo.
Per aprire il menu di programmazione, premere il tasto P. Successivamente impostare il tempo di immissione in camera del vapore con i tasti up e down posti a lato. Premere il tasto U per avviare l'immissione del vapore.



Steam generator instructions

Turn on the device with the switch placed next to the control display.
To open the time setting menu press P. Set then the steam introduction time, by using the up and down buttons on the side. Press U to start the steam introduction.

VAPORIERA CON PROGRAMMAZIONE DEL TEMPO DI IMMISSIONE

STEAM GENERATOR WITH PROGRAMMABLE STEAM INTRODUCTION TIME

TR LINE	4	4H	44	6	6H	66	6L	66L
DIMENSIONI INTERNE cm INSIDE DIMENSIONS cm	83 84 18	83 84 27	83 84 18 (x2)	83 124 18	83 124 27	83 124 18 (x2)	124 84 18	124 84 18 (x2)
DIMENSIONI ESTERNE cm OUTSIDE DIMENSIONS cm	113 98,5 41	113 98,5 50	113 98,5 75	113 140 41	113 140 50	113 140 75	154 98,5 41	154 98,5 75
DIMENSIONI IMBALLO cm PACKAGE DIMENSIONS cm	120 120 57	120 120 65	120 120 92	120 160 57	120 160 65	120 160 92	160 120 56	160 120 92
CAMERA COTTURA n° BAKING CHAMBER n°	1	1	2	1	1	2	1	2
POTENZA KW POWER KW	6.9	6.9	13.8	10.2	10.2	20.4	10.2	20.4
VOLT	400	400	400	400	400	400	400	400
TEMPERATURA °C TEMPERATURE °C	50/500°	50/500°	50/500°	50/500°	50/500°	50/500°	50/500°	50/500°
PESO Kg WEIGHT Kg	95	101	163	129	171	225	134	176
TOTALE PIZZE Ø 36 cm TOTAL PIZZA Ø 36 cm								
TEGLIE 60X40 cm PANS 60X40 cm	2	2	2+2	4	4	4+4	4	4+4
COD. TR D	7021521004	7021521004H	7021521044	7021521006	7021521006H	7021521066	7021521006L	7021521066L
COD. TR	7020521004	7020521004H	7020521044	7020521006	7020521006H	7020521066	7020521006L	7020521066L













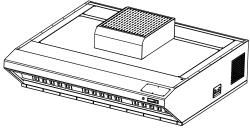

OPTIONAL PIETRA REFRATTARIA CIELO - OPTIONAL TOP REFRACTORY STONE

VAPORIERA - STEAMER

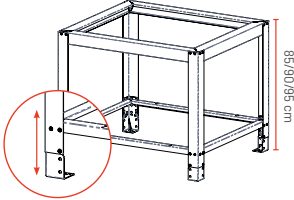
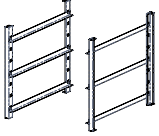

PIANO IN LAMIERA BUGNATA IDEALE PER COTTURA IN TEGLIE
(IN ALTERNATIVA ALLA PIETRA REFRATTARIA PLATEA)
BUCKLED PLATE IDEAL FOR COOKING IN PANS
(AS AN ALTERNATIVE TO THE BOTTOM REFRACTORY STONE)

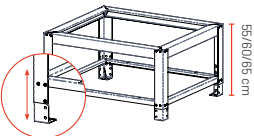
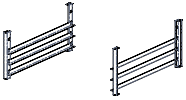

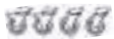
		DIMENSIONI cm DIMENSIONS cm	IMBALLO CM PACKAGE CM	PESO KG WEIGHT KG	OPTIONAL OPTIONAL	CODICE CODE
						
CAPPA INOX FORNO - OVENS INOX HOOD						
	4/44	114 113 11,5	120 115 20	13,00		7020120009
	6/66	114 156 11,5	120 160 20	18,00		7020120010
	6L/66L	155 113 11,5	160 120 20	18,00		7020120011
MOTORE ELETTRICO - ELETTRIC MOTOR						7020130001
CAPPA INOX FORNO A CONDENSAZIONE - OVENS INOX CONDENSATE EXHAUST HOOD						
	4/4/H	113 133 43	140 120 90	105,00		7020120209
	6/6/H	113 175 43	180 120 90	113,00		7020120210
	6L	154 133 43	140 160 90	120,00		7020120211
SUPPORTO REGOLABILE - ADJUSTABLE SUPPORT						
	4/44/H	114 99 85/90/95	120 30 20	27,00	/	7020100016
	6/66/H	114 140 85/90/95	145 30 20	30,00	/	7020100017
	6L/66L	155 99 85/90/95	160 30 20	30,00	/	7020100018
KIT PORTA TEGLIE - TRAYHOLDER KIT						
	4/44	/	105 30 20	6,50	/	7020110014
	6/66	/	150 30 20	7,50	/	7020110015
	6L/66L	/	105 30 20	12,00	/	7020110016
SUPPORTO REGOLABILE - ADJUSTABLE SUPPORT						
	4-4-4/H	114 99 55/60/65	120 30 20	23,50	/	7020100019
	6-6-6/H	114 140 55/60/65	145 30 20	26,50	/	7020100020
	6-6-6 L	155 99 55/60/65	160 30 20	26,50	/	7020100021
KIT PORTA TEGLIE - TRAYHOLDER KIT						
	4-4-4/H	/	105 30 30	5,00	/	7020110022
	6-6-6/H	/	150 30 30	6,50	/	7020110023
	6-6-6L	/	105 30 30	10,00	/	7020110024
COPPIA ANGOLARI - CORNERS COUPLE						
	4-44/6L-66L	/	90 10 10	1,30	/	7020110017
	6-66/6-6-6	/	90 10 10	1,80	/	7020110018
	KIT RUOTE - CASTORS KIT	+ 14 cm	30 20 20	5,00	/	7020110019

CELLA DI LIEVITAZIONE | PROVING CHAMBERS

ACCESSORIATO CON - EQUIPPED WITH



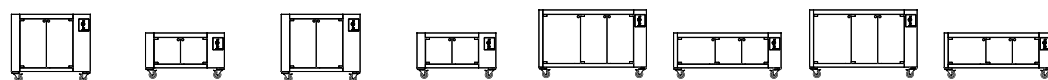

TS / TR	4-44-4H	4-4-4/H	6-66-6H	6-6-6/H	6L-66L	6-6-6 L	9-9	9-9-9
CAPACITÀ DI CARICO LOAD CAPACITY	14 TEGLIE 60X40	8 TEGLIE 60X40	14 TEGLIE 60X40	12 TEGLIE 60X40	21 TEGLIE 60X40	12 TEGLIE 60X40	24 TEGLIE 60X40	15 TEGLIE 60X40
SPAZIO TRA LE TEGLIE SPACE BETWEEN TRAYS	80 mm	80 mm	80 mm	80 mm	80 mm	80 mm	80 mm	80 mm
DIMENSIONI ESTERNE cm OUTSIDE DIMENSIONS cm	113x102x85 +14 ruote/wheels	113x102x52 +14 ruote/wheels	113x143x85 +14 ruote/wheels	113x143x52 +14 ruote/wheels	154x102x85 +14 ruote/wheels	154x102x52 +14 ruote/wheels	154x143x82 +14 ruote/wheels	154x143x61 +14 ruote/wheels
DIMENSIONI IMBALLO cm PACKAGE DIMENSIONS cm	120x120x100	120x120x67	160x120x100	160x120x67	160x120x100	160x120x67	155x146x82	155x146x61
POTENZA KW POWER KW	1,6 kW	1,6 kW	1,6 kW	1,6 kW	1,6 kW	1,6 kW	1,6 kW	1,6 kW
ALIMENTAZIONE POWER SUPPLY	230 - 1N 50-60 HZ	230 - 1N 50-60 HZ	230 - 1N 50-60 HZ	230 - 1N 50-60 HZ	230 - 1N 50-60 HZ	230 - 1N 50-60 HZ	230 - 1N 50-60 Hz	230 - 1N 50-60 Hz
TEMPERATURA °C TEMPERATURE °C	0/70°	0/70°	0/70°	0/70°	0/70°	0/70°	0/70°	0/70°
PESO Kg WEIGHT Kg	80 kg	69 kg	87 kg	76 kg	89 kg	78 kg	158 kg	127 kg
ABBINABILE AI FORNI CAN BE COMBINED TO THE OVENS	4 - 44 - 4H	4 X 3 - 4H	6 - 66 - 6H	6 X 3 - 6H	6 L - 66 L	6 L X 3	9 X 2	9 X 3
COD.	7020150001	7020150002	7020150003	7020150004	7020150005	7020150006	7020150007	7020150008

TECPRO LINE

Forno elettrico ideale per pizza al piatto e pasticceria, adatto a medi volumi di lavoro

Electric oven ideal for round pizza and pastry, suitable for medium volumes of work



TECPRO D (digitale)





Pannello di controllo digitale / Digital control panel



Pannello di controllo elettromeccanico / Electromechanical control panel



Valvola di regolazione umidità / Humidity regulation valve



Cappa con motore elettrico opzionale / Hood with electric motor as optional

Caratteristiche TECPRO D (digitale)

- Da 4 a 18 pizze diam. 36Cm ø
- Da 1 a 8 teglie
- Valvola di regolazione umidità
- Gestione del calore de cielo e della platea con percentuale, per una maggiore precisione e risparmio energetico
- Funzione power boost
- Timer di cottura
- Sportello ad apertura controllata (sistema a molle certificato), vetro ceramico ad alto isolamento termico.
- Guarnizione per migliore isolamento termico della camera di cottura.
- Doppio strato di coibentazione in "ecoblanc"
- Posizionabile su celle di lievitazione di nostra produzione (temp. Max 70°)
- Maggiore efficienza e attenzione all'ambiente: coibentazione in "ecoblanc", riciclabile ed ecocompatibile, oltre a garantire un altissimo risparmio energetico, assicura zero dispersione, durante la manutenzione, rispetto alla lana di roccia
- Piano refrattario di serie sostituibile con piano in lamiera bugnata (su richiesta)

Features TECPRO D (digital)

- From 4 to 18 pizza diam. 36Cm ø
- From 1 to 8 trays
- Humidity regulation valve
- Percentage regulation of the heat intensity on the top and the base, for a higher precision and energy saving
- Power boost function
- Cooking timer
- Door equipped with certified soft opening spring system, high insulation ceramic glass to have a more uniform cooking temperature.
- Additional insulating seal on the chamber frame, with internal spiral spring for thickness return.
- Double insulation layer in "ecoblanc"
- It can be placed on proving chambers of our production (max temp. 70°)
- Higher energy efficiency and attention to the environment: insulation system "ecoblanc", eliminating the decay of the mineral wool.
- Replaceable standard refractory top with embossed plate top (on request)

Caratteristiche TECPRO (elettromeccanico)



- Da 4 a 18 pizze diam. 36Cm ø
- Da 1 a 8 teglie
- Valvola di regolazione umidità
- Termostati comandati da scheda relè
- Gestione separata della potenza di cielo e platea
- Accensione separata resistenze cielo e platea
- Doppio strato di coibentazione in "ecoblanc"
- Posizionabile su celle di lievitazione di nostra produzione (temp. Max 70°)
- Maggiore efficienza e attenzione all'ambiente: coibentazione in "ecoblanc", riciclabile ed ecocompatibile, oltre a garantire un altissimo risparmio energetico, assicura zero dispersione, durante la manutenzione, rispetto alla lana di roccia
- Piano refrattario di serie sostituibile con piano in lamiera bugnata (su richiesta)

Features TECPRO (electromechanical)

- From 4 to 18 pizza diam. 36Cm ø
- From 1 to 8 trays
- Humidity regulation valve
- Thermostats controlled by a relay card
- Base and top heating elements activated by separate switches
- Regulation of the heat intensity on the top and the base
- Double insulation layer in "ecoblanc"
- It can be placed on proving chambers of our production (max temp. 70°)
- Higher energy efficiency and attention to the environment: insulation system "ecoblanc", eliminating the decay of the mineral wool.
- Replaceable standard refractory top with embossed plate top (on request)

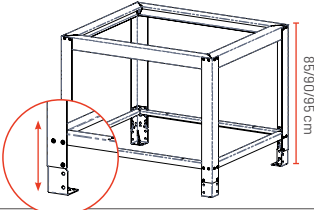
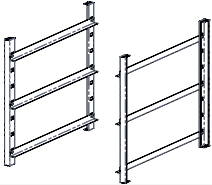
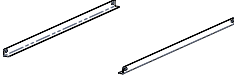

TECPRO LINE	4	44	6	66	9	99	6 BIG L	66 BIG L
DIMENSIONI INTERNE cm INSIDE DIMENSIONS cm	72 72 14	72 72 14(x2)	72 108 14	72 108 14(x2)	108 108 14	108 108 14(x2)	108 72 14	108 72 14(x2)
DIMENSIONI ESTERNE cm OUTSIDE DIMENSIONS cm	95 90,5 39,5	95,0 90,5 71	95 126,5 39,5	95 126,5 71	131 126,5 39,5	131 126,5 71	131 90,5 39,5	131 90,5 71
DIMENSIONI IMBALLO cm PACKAGE DIMENSIONS cm	100 100 56	100 100 88	140 100 56	140 100 88	140 140 56	140 140 88	140 100 56	140 100 88
CAMERA COTTURA n° BAKING CHAMBER n°	1	2	1	2	1	2	1	2
POTENZA KW POWER KW	6.0	12	9.0	18.0	13.8	27.6	9.2	18.4
VOLT	230/400	230/400	400	400	400	400	230/400	230/400
TEMPERATURA °C TEMPERATURE °C	50/500°	50/500°	50/500°	50/500°	50/500°	50/500°	50/500°	50/500°
PESO Kg WEIGHT Kg	72	125	102	159	128	224	96	168
TOTALE PIZZE Ø 36 cm TOTAL PIZZA Ø 36 cm								
TEGLIE 60X40 cm PANS 60X40 cm	1	1+1	2	2+2	4	4+4	2	2+2
COD. TECPRO D	7021421004	7021421044	7021421006	7021421066	7021421009	7021421099	7021421006L	7021421066L
COD. TECPRO	7020421004	7020421044	7020421006	7020421066	7020421009	7020421099	7020421006L	7020421066L

		DIMENSIONI cm DIMENSIONS cm	IMBALLO CM PACKAGE CM	PESO KG WEIGHT KG	OPTIONAL OPTIONAL	CODICE CODE
CAPPA INOX FORNO - OVENS INOX HOOD						
	4/44	95 102 11,5	99 106 20	11,00	✓	7020120003
	6/66	95 138 11,5	99 142 20	13,00	✓	7020120004
	9/99	131 138 11,5	135 142 20	17,00	✓	7020120005
	6L/66L	131 102 11,5	135 106 20	13,50	✓	7020120006
MOTORE ELETTRICO - ELETTRIC MOTOR					✓	7020130001
SUPPORTO REGOLABILE - ADJUSTABLE SUPPORT						
	4/44	96 91 85/90/95	105 30 20	25,00	/	7020100005
	6/66	96 127 85/90/95	130 30 20	28,00	/	7020100006
	9/99	132 127 85/90/95	140 30 20	30,00	/	7020100009
	6L/66L	132 91 85/90/95	140 30 20	28,00	/	7020100011
KIT PORTA TEGLIE - TRAYHOLDER KIT						
	4/44	/	100 30 20	6,00	/	7020110006
	6/66	/	130 30 20	7,00	/	7020110008
	9/99	/	140 30 20	7,00	/	7020110008
	6L/66L	/	140 30 20	6,00	/	7020110006
COPPIA ANGOLARI - CORNERS COUPLE						
	4 - 44 - 6L - 66L	/	90 10 10	1,20	/	7020110011
	6 - 66 - 9 - 99	/	130 10 10	1,60	/	7020110013
	KIT RUOTE - CASTORS KIT	+ 14 cm	30 20 20	5,00	/	7020110001

OPTIONAL PIETRA REFRATTARIA CIELO - OPTIONAL TOP REFRACTORY STONE

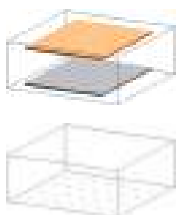

PIANO IN LAMIERA BUGNATA IDEALE PER COTTURA IN TEGLIE
(IN ALTERNATIVA ALLA PIETRA REFRATTARIA PLATEA)
BUCKLED PLATE IDEAL FOR COOKING IN PANS
(AS AN ALTERNATIVE TO THE BOTTOM REFRACTORY STONE)

TL LINE

Forno elettrico base compatto per pizzeria e focacceria, disponibile in versione digitale ed elettromeccanica

Compact electric oven for pizza and focaccia, available in both digital and electromechanical version



TL D (digitale)





Pannello di controllo digitale / Digital control panel



Pannello di controllo elettromeccanico / Electromechanical control panel



Caratteristiche TL D (digitale)

- Da 4 a 18 pizze diam. 36Cm ø
- Da 1 a 8 teglie
- Pietra cielo opzionale
- Gestione del calore de cielo e della platea con percentuale, per una maggiore precisione e risparmio energetico
- Funzione Power Boost
- Timer di cottura
- Maggiore efficienza e attenzione all'ambiente: coibentazione in "ecoblanc", riciclabile ed ecocompatibile, oltre a garantire un altissimo risparmio energetico, assicura zero dispersione, durante la manutenzione, rispetto alla lana di roccia
- Piano refrattario di serie sostituibile con piano in lamiera bugnata (su richiesta)

Features TL D (digital)

- From 4 to 18 pizza diam. 36Cm ø
- From 1 to 8 trays
- Refractory stone available for top
- Percentage regulation of the heat intensity on the top and the base, for a higher precision and energy saving
- Power Boost function
- Cooking timer
- Higher energy efficiency and attention to the environment: insulation system "ecoblanc", eliminating the decay of the mineral wool
- Replaceable standard refractory top with embossed plate top (on request)

Caratteristiche TL (elettromeccanico)

- Da 4 a 18 pizze diam. 36Cm ø
- Da 1 a 8 teglie
- Scarico fumi (sempre aperto)
- Gestione separata della potenza di cielo e platea
- Termostati comandati da scheda relè
- Accensione separata resistenze cielo e platea
- Pietra cielo opzionale
- Maggiore efficienza e attenzione all'ambiente: coibentazione in "ecoblanc", riciclabile ed ecocompatibile, oltre a garantire un altissimo risparmio energetico, assicura zero dispersione, durante la manutenzione, rispetto alla lana di roccia
- Piano refrattario di serie sostituibile con piano in lamiera bugnata (su richiesta)

Features TL (electromechanical)

- From 4 to 18 pizza diam. 36Cm ø
- From 1 to 8 trays
- Steam exhaust (always open)
- Regulation of the heat intensity on the top and the base
- Thermostats controlled by a relay card
- Base and top heating elements activated by separate switches
- Refractory stone available for top
- Higher energy efficiency and attention to the environment: insulation system "ecoblanc", eliminating the decay of the mineral wool
- Replaceable standard refractory top with embossed plate top (on request)



TL LINE

	4	44	6	66	9	99	6L	66L
DIMENSIONI INTERNE cm INSIDE DIMENSIONS cm	72 72 14	72 72 14(x2)	72 108 14	72 108 14(x2)	108 108 14	108 108 14(x2)	108 72 14	108 72 14(x2)
DIMENSIONI ESTERNE cm OUTSIDE DIMENSIONS cm	95 86,5 39,5	95 86,5 71	95 122,5 39,5	95 122,5 71	131 122,5 39,5	131 122,5 71	131 86,5 39,5	131 86,5 71
DIMENSIONI IMBALLO cm PACKAGE DIMENSIONS cm	97 100 56	97 100 88	97 140 56	97 140 88	133 135 56	133 135 88	133 99 56	133 99 88
CAMERA COTTURA n° BAKING CHAMBER n°	1	2	1	2	1	2	1	2
POTENZA KW POWER KW	6.0	12	9.0	18.0	13.8	27.6	9.2	18.4
VOLT	230/400	230/400	400	400	400	400	230/400	230/400
TEMPERATURA °C TEMPERATURE °C	50/500°	50/500°	50/500°	50/500°	50/500°	50/500°	50/500°	50/500°
PESO Kg WEIGHT Kg	62	110	92	149	117	207	89	149
TOTALE PIZZE Ø 36 cm TOTAL PIZZA Ø 36 cm								
TEGLIE 60X40 cm PANS 60X40 cm	1	1+1	2	2+2	4	4+4	2	2+2
COD. TL D	7021321004B	7021321044B	7021321006B	7021321066B	7021321009B	7021321099B	7021321006BL	7021321066BL
COD. TL	7020321004B	7020321044B	7020321006B	7020321066B	7020321009B	7020321099B	7020321006BL	7020321066BL

	DIMENSIONI cm DIMENSIONS cm	IMBALLO CM PACKAGE CM	PESO KG WEIGHT KG	OPTIONAL OPTIONAL	CODICE CODE
--	--------------------------------	--------------------------	----------------------	----------------------	----------------

CAPPA INOX FORNO - OVENS INOX HOOD

	4/44	95 102 11,5	99 106 20	11,00		7020120003
	6/66	95 138 11,5	99 142 20	13,00	✓	7020120004
	9/99	131 138 11,5	135 142 20	17,00	✓	7020120005
	6L/66L	131 102 11,5	135 106 20	13,50	✓	7020120006

MOTORE ELETTRICO - ELETTRIC MOTOR

✓ 7020130001

SUPPORTO REGOLABILE - ADJUSTABLE SUPPORT

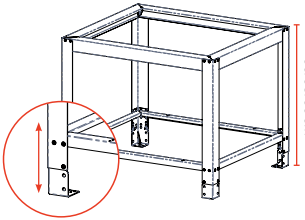

✓

	4/44	96 91 85/90/95	105 30 20	25,00	/	7020100005
	6/66	96 127 85/90/95	130 30 20	28,00	/	7020100006
	9/99	132 127 85/90/95	140 30 20	30,00	/	7020100009
	6L/66L	132 91 85/90/95	140 30 20	28,00	/	7020100011

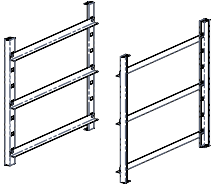
KIT PORTA TEGLIE - TRAYHOLDER KIT

	4/44	/	100 30 20	6,00	/	7020110006
	6/66	/	130 30 20	7,00	/	7020110008
	9/99	/	140 30 20	7,00	/	7020110008
	6L/66L	/	140 30 20	6,00	/	7020110006

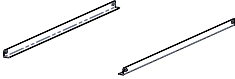
COPPIA ANGOLARI - CORNERS COUPLE

	4/44 - 6L/66L	/	90 10 10	1,20	/	7020110011
	6/66 - 9/99	/	130 10 10	1,60	/	7020110013
	KIT RUOTE - CASTORS KIT - RÄDERSÄTZE KIT ROUES - KIT RUEDAS	+ 14 cm	30 20 20	5,00	/	7020110001

OPTIONAL PIETRA REFRATTARIA CIELO - OPTIONAL TOP REFRACTORY STONE

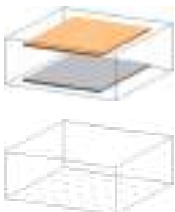

PIANO IN LAMIERA BUGNATA IDEALE PER COTTURA IN TEGLIE
(IN ALTERNATIVA ALLA PIETRA REFRATTARIA PLATEA)
BUCKLED PLATE IDEAL FOR COOKING IN PANS
(AS AN ALTERNATIVE TO THE BOTTOM REFRACTORY STONE)

KUBE LINE

Forno elettrico da banco per cottura/rigenerazione di pizza in pala e pizza in teglia

Countertop electric oven for cooking/regeneration of shovel pizza and tray pizza



KUBE EVO





Cappa di aspirazione con filtro a carboni attivi
Extractor hood with an activated carbon filter

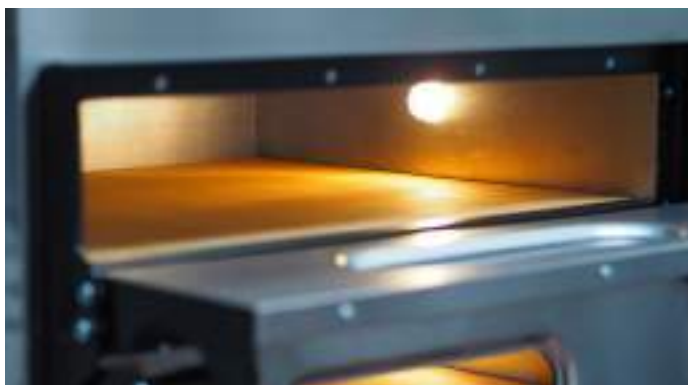

Interno camera / Internal chamber



Maniglia / Door handle



Quadro comandi / Control panel

Caratteristiche

- Il punto forte è l'idea di porre i comandi sotto lo sportello, ottenendo un forno più compatto.
- La dimensione esterna 74x60x41 è ideale per bar con spazi ridotti che vogliono servire una pizza professionale
- Max 2 pizze da 32cm ø o 1 teglia per camera
- Temperatura di lavoro max. 400°
- Struttura in acciaio
- 2-3-4 Termostati
- Corrente monofase o trifase
- La versione a 2 camere monta 3 resistenze (la centrale lavora per entrambe le camere) ed è stata concepita per cuocere in una camera e scaldare nell'altra.
- La versione Plus a 2 camere monta 4 resistenze

Features

- The control knobs are placed under the door : a smart and space saving solution.
- The external dimension 74x60x41 perfectly fits bar and pub counters that want to offer a professional pizza
- Max 2 pizza diam. 32Cm ø or 1 tray in each chamber
- Max. Temperature 400° (pyrolysis recommended at 400°)
- Structure in stainless steel and pre-painted sheet
- 2-3-4 Thermostats
- Monophase or triphase current
- The 2 chambers version is equipped with 3 heating elements (the central one works for both chambers) and has been created to cook in one chamber and heat up on the other.
- Plus version with 2 chambers has 4 heating elements

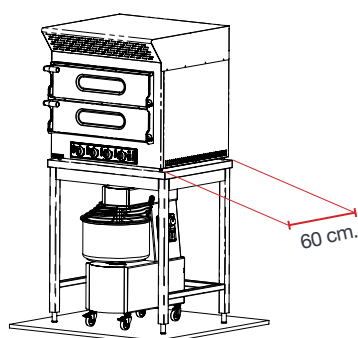



KUBE EVO

è un forno con cappa di aspirazione con filtro a carboni attivi, può essere la soluzione per coloro che non hanno o non possono installare la canna fumaria.

KUBE EVO

is an oven with an extractor hood with an activated carbon filter, it can be the solution for those who do not have or cannot install the chimney.

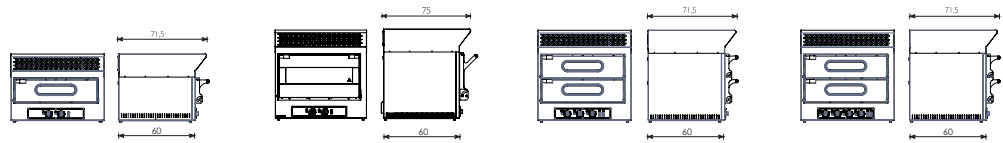

KUBE EVO

1 EVO

1H EVO

2 EVO

2 PLUS EVO

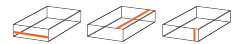
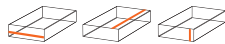

DIMENSIONI INTERNE cm
INSIDE DIMENSIONS cm

61 52 11

61 52 27

61 52 11(x2)

61 52 11(x2)

DIMENSIONI ESTERNE cm
OUTSIDE DIMENSIONS cm

74 60/71,5 55

74 60/75 74

74 60/71,5 74

74 60/ 71,5 74

DIMENSIONI IMBALLO cm
PACKAGE DIMENSIONS cm

80 80 75

80 80 90

80 80 90

80 80 90

CAMERA COTTURA n°
BAKING CHAMBER n°

1

1

2

2

RESISTENZE
HEATING ELEMENTS

2

2

3

4

POTENZA KW
POWER KW

3.2

3.2

4.8

6.4

VOLT

230

230/400

230/400

400

TEMPERATURA °C
TEMPERATURE °C

50/508°

50/508°

50/508°

50/508°

PESO Kg
WEIGHT Kg

59

79

79

79

TOTALE PIZZE Ø 30 cm
TOTAL PIZZA Ø 30 cm



TEGLIE 60X40 cm
PANS 60X40 cm

1

1+1

1+1

1+1

COD.

7020121001K

7020121001HK

7020121002K

7020121003K



KUBE

Il forno elettrico ideale per bar e take away

Costruito in acciaio inox, lamiera preverniciata con camera di cottura in lamiera alluminata. Piano di cottura in pietra refrattaria. Isolamento in lana di roccia evaporata. Resistenze corazzate. Illuminazione interna.

KUBE

The electric oven perfect for coffee bar and take away

in stainless steel and coated metal sheet, the baking chamber is made in covered aluminium steel plate. Firestone cooking top. Evaporated mineral wool insulation. Armored resistances. Interior lighting.

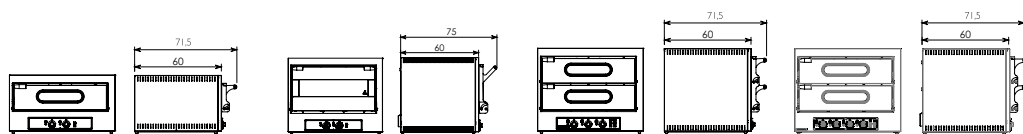

KUBE	1	1H	2	2 PLUS
DIMENSIONI INTERNE cm INSIDE DIMENSIONS cm	61 52 11	61 52 27	61 52 11(x2)	61 52 11(x2)
DIMENSIONI ESTERNE cm OUTSIDE DIMENSIONS cm	74 60/71,5 41	74 60/75 60	74 60/71,5 60	74 60/71,5 60
DIMENSIONI IMBALLO cm PACKAGE DIMENSIONS cm	80 80 55	80 80 75	80 80 74	80 80 74
CAMERA COTTURA n° BAKING CHAMBER n°	1	1	2	2
RESISTENZE HEATING ELEMENTS	2	2	3	4
POTENZA KW POWER KW	3.2	3.2	4.8	6.4
VOLT	230	230/400	230/400	400
TEMPERATURA °C TEMPERATURE °C	50/508°	50/508°	50/508°	50/508°
PESO Kg WEIGHT Kg	46,5	66,5	66,5	66,5
TOTALE PIZZE Ø 30 cm TOTAL PIZZA Ø 30 cm				
TEGLIE 60X40 cm PANS 60X40 cm	1	1+1	1+1	1+1
COD.	7020121001	7020121001H	7020121002	7020121003

SMALL LINE

Forno elettrico da banco per cottura/rigenerazione di pizza e focacceria

Countertop electric oven for cooking/regeneration of pizza and focaccia





SMALL G



SMALL E



SMALL C



SMALL B

SMALL B

Caratteristiche base

- Max 1 pizza da 32cm ø per camera
- Temperatura di lavoro max. 320°
- Struttura in lamiera verniciata
- 1 Termostato + 1 timer
- Corrente monofase
- La versione a 2 camere monta 3 resistenze (la centrale lavora per entrambe le camere)
- Camera inferiore ideale per cottura, quella superiore per riscaldare

Basic features

- Max. 1 Pizza diam. 32Cm ø each chamber
- Max. Temperature 320°
- Structure in pre-painted sheet
- 1 Thermostat + 1 timer
- Monophase current
- The 2 chambers version is equipped with 3 heating elements (the central one works for both chambers)
- Lower chamber ideal for cooking, upper chamber to heat up

SMALL C

in più

- Il vetro sullo sportello per controllare il prodotto durante la cottura

more

- The glass on the door to check the cooking process

SMALL E

in più

- Struttura in acciaio inox
- Illuminazione interna
- 4 Resistenze nella versione a due camere
- Maggiore coibentazione e isolamento delle camere tra loro

more

- Structure in stainless steel
- Internal light
- 4 Heating elements in the 2 chambers version
- Higher insulation and separation of the 2 chambers

SMALL G

in più

- Maggiore coibentazione e isolamento delle Camere tra loro
- Maggiore precisione e risparmio energetico
- 2 Termostati per camera
- Vetro sullo sportello per controllare il prodotto durante la cottura
- Temperatura max. 350°

more

- Higher insulation and separation of the 2 chambers
- Higher precision and energy saving
- 2 Thermostats on each chamber
- Glass door to check the cooking process
- Max. Temperature 350°



SMALL LINE

	B	B2	C	C2	E	E2
DIMENSIONI INTERNE cm INSIDE DIMENSIONS cm	41 36 11	41 36 11(x2)	41 36 11	41 36 11(x2)	41 36 11	41 36 11(x2)
DIMENSIONI ESTERNE cm OUTSIDE DIMENSIONS cm	55 43 25,5	55 43 43,5	55 43 25,5	55 43 43,5	55 43 25,5	55 43 43,5
DIMENSIONI IMBALLO cm PACKAGE DIMENSIONS cm	60 50 28	60 50 46	60 50 28	60 50 46	60 50 28	60 50 46
CAMERA COTTURA n° BAKING CHAMBER n°	1	2	1	2	1	2
POTENZA KW POWER KW	1.6	2.4	1.6	2.4	1.6	3.2
VOLT	230	230	230	230	230	230
TEMPERATURA °C TEMPERATURE °C	0/320°	0/320°	0/320°	0/320°	0/320°	0/320°
PESO Kg WEIGHT Kg	17	29	17	29	17	29
TOTALE PIZZE Ø 36 cm TOTAL PIZZA Ø 36 cm						
COD.	7020121001B	7020121002B	7020121001C	7020121002C	7020121001E	7020121002E



SMALL LINE	G	G2
DIMENSIONI INTERNE cm INSIDE DIMENSIONS cm	41 36 11	41 36 11(x2)
DIMENSIONI ESTERNE cm OUTSIDE DIMENSIONS cm	55 43 25,5	55 43 43,5
DIMENSIONI IMBALLO cm PACKAGE DIMENSIONS cm	60 50 28	60 50 46
CAMERA COTTURA n° BAKING CHAMBER n°	1	2
POTENZA KW POWER KW	1.6	3.2
VOLT	230	230
TEMPERATURA °C TEMPERATURE °C	0/350°	0/350°
PESO Kg WEIGHT Kg	17	30
TOTALE PIZZE Ø 36 cm TOTAL PIZZA Ø 36 cm		
COD.	7020121001G	7020121002G

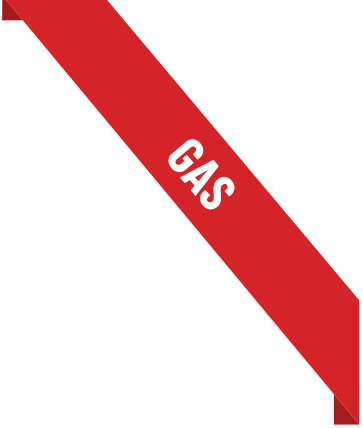

RG LINE

Forno a gas modulare ideale per pizza

Modular gas oven ideal for pizza





Gestione separata di cielo e platea / Separate control of the heat intensity



Interno camera / Internal chamber

Caratteristiche

Sono costruiti in acciaio inox e in lamiera preverniciata. Piano di cottura in pietra refrattaria. Isolamento in lana di roccia evaporata. Scarico vapori a centro camera. Illuminazione interna. Alimentazione a gas con valvole di sicurezza con ugelli installati per GPL ed in dotazioni quelli per il gas metano. Bruciatori posti sotto la pietra. Progettati per cucinare ottimamente le pizze più fantasiose e raffinati piatti di gastronomia.

I nostri forni gas RG, danno la possibilità di controllare separatamente l'intensità del calore su cielo e platea.

Features

Is made of stainless steel and coated metal sheet. Firestone cook top. Evaporated mineral wool isolation. Vapors exhaust at the center of backing chamber. Interior lighting. Gas supply with safety valves with installed nozzles for LPG and equipped with those for the methane gas. Burners placed under the stone. Designed to cook the perfect pizza and sophisticated dishes.

Our ovens RG allow the user a separate control of the heat intensity on the top and the base of the cooking chamber.

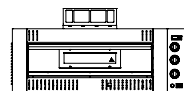
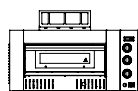
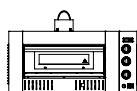

RG LINE

	4	6	9
DIMENSIONI INTERNE cm INSIDE DIMENSIONS cm	62 62 15,5	62 92 15,5	92 92 15,5
DIMENSIONI ESTERNE cm OUTSIDE DIMENSIONS cm	100 84 47,5	100 114 47,5	130 114 47,5
DIMENSIONI IMBALLO cm PACKAGE DIMENSIONS cm	100 100 64	100 135 64	135 135 64
CAMERA COTTURA n° BAKING CHAMBER n°	1	1	1
BRUCIATORI n° BURNERS N°	4	4	6
POTENZA KW POWER KW	13.2	21.0	27.0
TEMPERATURA °C TEMPERATURE °C	450°	450°	450°
PESO Kg WEIGHT Kg	104	120	163
TOTALE PIZZE Ø 30 cm TOTAL PIZZA Ø 30 cm			
TEGLIE 60X40 cm PANS 60X40 cm	1	2	2
COD.	7020221RG4	7020221RG6	7020221RG9

Specificare tipo di gas: metano o GPL (butano o propano)
Specify methane gas or LPG (butane or propane)

I forni sono sovrapponibili uno sopra l'altro per un massimo di due
The ovens are stackable one above the other for a maximum of two

Schema di installazione forni linea RG
Oven technical setting diagram

Tipo A1 - Type A1 - Typ A1 - Type A1 - Tipo A1
Tipo B21 - Type B21 - Typ B21 - Type B21 - Tipo B21
Tipo B11 - Type B11 - Typ B11 - Type B11 - Tipo B11

Cappa
Hood

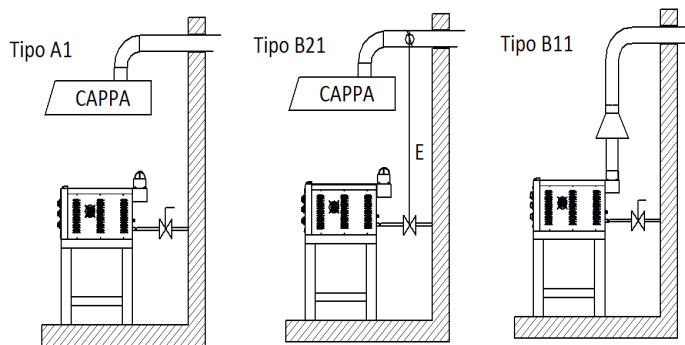

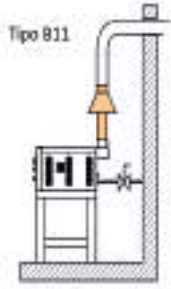



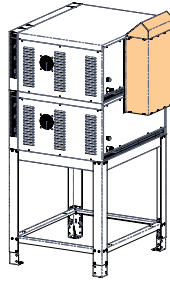

Tipo B11 - Type B11 - Typ B11 - Type B11 - Tipo B11

Nota: il Camino antivento viene fornito a richiesta.
 Note: The Chimney is supplied on request.



Nota: Il raccordo fumi verrà fornito a richiesta.
 Note: The exhauster connection for stackable ovens is supplied on request.

		DIMENSIONI cm DIMENSIONS cm 	IMBALLO cm PACKAGE cm 	WEIGHT Kg	OPTIONAL	CODICE
	CAMINO ANTIVENTO CHIMNEY	46 36 89	50 42 61	7,00	/	7020120007
	RACCORDO FUMI PER SOVRAPPORRE FORNO EXHAUSTER CONNECTION FOR STACKABLE OVENS	46 21 75	48 23 76	8,50	/	7020120008

SUPPORTO REGOLABILE - ADJUSTABLE SUPPORT

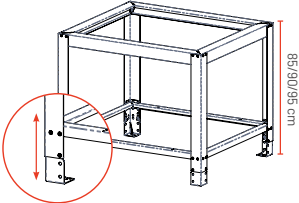
	4	101 91 85/90/95	105 30 20	25,50	/	7020100013
	6	101 116 85/90/95	130 30 20	27,00	/	7020100014
	9	132 116 85/90/95	140 30 20	29,00	/	7020100015

KIT PORTA TEGLIE - TRAYHOLDER KIT

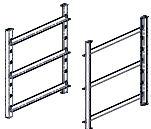
	4	/	100 30 20	5,00	/	7020110006
	6/9	/	130 30 20	6,50	/	7020110004

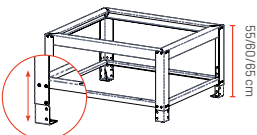

SUPPORTO REGOLABILE - ADJUSTABLE SUPPORT

	4+4	101 91 55/60/65	105 30 20	22,00	/	7020100023
	6+6	101 116 55/60/65	130 30 20	23,50	/	7020100024
	9+9	132 116 55/60/65	140 30 20	25,50	/	7020100025

KIT PORTA TEGLIE - TRAYHOLDER KIT

	4+4	/	100 30 20	4,50	/	7020110025
	6+6 / 9+9	/	130 30 20	6,00	/	7020110026

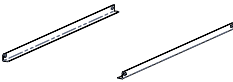
COPPIA ANGOLARI - CORNERS COUPLE

	4	/	90 10 10	1,10	/	7020110011
	6 / 9	/	130 10 10	1,50	/	7020110012
	KIT RUOTE - CASTORS KIT	+ 14 cm	30 20 20	5,00	/	7020110019

Accessories Pizza Line



PALA RETTANGOLARE - RECTANGULAR PEELS

Manico in acciaio inox | Stainless steel

	PR41	PR32
DIMENSIONI - DIMENSIONS	223 cm	107 cm
PESO - WEIGHT	1,320 Kg	0,587 Kg
CODICE - CODE	7020160001	7020160003



PALETTINA | SMALL PEELS - KLEINE SCHAUFEL

Manico in acciaio inox - Stainless steel

	PRP
DIMENSIONI - DIMENSIONS	180 cm
PESO - WEIGHT	1,034 Kg
CODICE - CODE	7020160002



APPENDI PALE - PEEL RACK

A parete 3 posti (pala, palettino, spazzola) - Wall-mounted 3 places (peel, small peel, brush)

	APP3
DIMENSIONI - DIMENSIONS	41X8 cm
PESO - WEIGHT	0,264 Kg
CODICE - CODE	7020160004



SPAZZOLA - BRUSH - BÜRSTE - BROSSE - CEPILLO

Setole Naturali - Natural bristles

	SPAZ SN
DIMENSIONI - DIMENSIONS	191 - 20X6,6 cm
PESO - WEIGHT	0,722 Kg
CODICE - CODE	7020160005



RICAMBIO SPAZZOLA - BRUSH REPLACEMENT

	RICSPAZ
DIMENSIONI - DIMENSIONS	20X6,6 cm
PESO - WEIGHT	0,274 Kg
CODICE - CODE	7020160006



SPAZZOLA CON SETOLE IN OTTONE - BRUSH WITH BRASS BRISTLES

	SPAZ SP
DIMENSIONI - DIMENSIONS	129 - 16X5 cm
PESO - WEIGHT	0,520 Kg
CODICE - CODE	7020160007



GANCIO PER TEGLIE - PAN HOOK

	GAN
DIMENSIONI - DIMENSIONS	0,15 Kg
PESO - WEIGHT	7020160008



TAGLIAPASTA - DOUGH-CUTTERS

Antiurto e antigraffio - Impact-resistant and scratch-resistant

	TAGL
DIMENSIONI - DIMENSIONS	13,5 - 14X5 cm
PESO - WEIGHT	0,14 Kg
CODICE - CODE	7020160009



PALETTA RETTANGOLARE - RECTANGULAR PIZZA-SERVER

Flessibile - Flexible

	PRP10
DIMENSIONI - DIMENSIONS	10X13 cm
PESO - WEIGHT	0,170 Kg
CODICE - CODE	7020160010



PALETTA TRIANGOLARE - TRIANGULAR PIZZA-SERVER

	PRP14
DIMENSIONI - DIMENSIONS	14,5X19 cm
PESO - WEIGHT	0,300 Kg
CODICE - CODE	7020160011



PINZA PER TEGLIE - TRAY GRIPPERS

Altezza regolabile - Adjustable height

	PINZ
DIMENSIONI - DIMENSIONS	9X24 cm
PESO - WEIGHT	0,275 Kg
CODICE - CODE	7020160012



TEGLIA RETTANGOLARE - RECTANGULAR PAN

Bordo dritto 2 cm - 2 cm straight edge

	TEGL
DIMENSIONI - DIMENSIONS	40X60 cm
PESO - WEIGHT	1,850 Kg
CODICE - CODE	7020160014



TEGLIA BAGUETTE - BAGUETTE PAN

	TEGL
DIMENSIONI - DIMENSIONS	40X60 cm
CANALI - CANALS	6
PESO - WEIGHT	1,800 Kg
CODICE - CODE	7020160015



CASSETTA IN PLASTICA - PLASTIC CASE

	CASSPL
DIMENSIONI - DIMENSIONS	60X40X10 cm
PESO - WEIGHT	1,300 Kg
CODICE - CODE	7020160016







Preparazione Impasto Kneading Preparation

SKV LINE

Impastatrice a spirale a velocità variabile

Spiral mixer with variable speed



Adatta a tutti i tipi di idratazione

Suitable for each type of hydration





Pannello di controllo digitale con inversione di marcia di serie
Digital control panel with reverse direction as standard



Spaccapasta e spirale in acciaio INOX
Dough breaker and spiral in stainless steel

Caratteristiche

- Vasca, spirale, spaccapasta in acciaio inox 304
- Trasmissione a catena con motoriduttore a bagno d'olio per riduzione della rumorosità
- Stop di emergenza attivato da sollevamento griglia
- Timer e ruote di serie
- 50 livelli di velocità
- Alimentazione monofase
- Display comandi digitale
- Software salva-motore: in caso di lavorazione impasti scarsamente idratati a velocità eccessiva, riduce i giri spirale adeguatamente onde evitare danni irreversibili.

Disponibilità di motori con frequenza a 60HZ, certificati UL ed a 240V con spina inglese.

Features

- Bowl, spiral, dough breaker in stainless steel 304
- Chain transmission with gearmotor in oil bath to reduce the operating noise.
- Emergency stop activated by lifting the protection grid
- Timer and wheels included
- 50 speed levels
- Works with monophase current
- Digital display
- Engine-saving software: in case the operators sets a high speed for working a too hard dough, it reduces the rounds of the spiral to avoid permanent damages

Availability of motors with 60HZ frequency, UL certified and 240V with english plug.

+ 9,5 cm



Ruote e timer di serie
Castors and timer included



Manopola per velocità variabile
Knob for variable speed

SKV 10

VOLUME VASCA BOWL VOLUME	CAPACITÀ CAPACITY	DIMENSIONE VASCA cm DIMENSIONS CUVE cm	DIMENSIONI ESTERNE cm OUTSIDE DIMENSIONS cm	DIMENSIONI IMBALLO cm PACKAGE DIMENSIONS cm
7 lt	6 Kg	24 Ø 16 h	29 46 56 h	39 52 75 h

SKV 10 MO _ 230 V

MONOFASE
MONOPHASE

	POTENZA - POWER	PESO - WEIGHT	RPM		COD.
SKV 10 MO	0.35 Hp / 0,22 KW	31Kg	42/182	6/26	7010151010

MACCHINA CON INVERIONE DI MARCIA
MACHINE WITH REVERSE DIRECTION FUNCTION

SKV 20

VOLUME VASCA BOWL VOLUME	CAPACITÀ CAPACITY	DIMENSIONE VASCA cm DIMENSIONS CUVE cm	DIMENSIONI ESTERNE cm OUTSIDE DIMENSIONS cm	DIMENSIONI IMBALLO cm PACKAGE DIMENSIONS cm
21 lt	17 Kg	36 Ø 21 h	40 67,5 75 h	45 77 93 h

SKV 20 MO _ 230 V

MONOFASE
MONOPHASE

	POTENZA - POWER	PESO - WEIGHT	RPM		COD.
SKV 20 MO	1 Hp / 0,75 KW	63 Kg	51/221	6/26	7010151020

MACCHINA CON INVERIONE DI MARCIA
MACHINE WITH REVERSE DIRECTION FUNCTION

SKV 30

VOLUME VASCA BOWL VOLUME	CAPACITÀ CAPACITY	DIMENSIONE VASCA cm DIMENSIONS CUVE cm	DIMENSIONI ESTERNE cm OUTSIDE DIMENSIONS cm	DIMENSIONI IMBALLO cm PACKAGE DIMENSIONS cm
32 lt	25 Kg	40 Ø 26 h	44 74,5 84 h	51 79 102 h

SKV 30 MO _ 230 V

MONOFASE
MONOPHASE

	POTENZA - POWER	PESO - WEIGHT	RPM		COD.
SKV 30 MO	2 Hp / 1,5 KW	86 Kg	55/239	6/26	7010151030

MACCHINA CON INVERIONE DI MARCIA
MACHINE WITH REVERSE DIRECTION FUNCTION

SKV 40

VOLUME VASCA BOWL VOLUME	CAPACITÀ CAPACITY	DIMENSIONE VASCA cm DIMENSIONS CUVE cm	DIMENSIONI ESTERNE cm OUTSIDE DIMESIONS cm	DIMENSIONI IMBALLO cm PACKAGE DIMENSIONS cm
41 lt	36 Kg	45 Ø 26 h	49,5 80 86 h	57 85 103 h

SKV 40 MO _ 230 V

MONOFASE
MONOPHASE

	POTENZA - POWER	PESO - WEIGHT	RPM	COD.
SKV 40 MO	3 Hp / 2,2 KW	100 Kg	55/239 6/26	7010151040

MACCHINA CON INVERIONE DI MARCIA
MACHINE WITH REVERSE DIRECTION FUNCTION

SKV 50

VOLUME VASCA BOWL VOLUME	CAPACITÀ CAPACITY	DIMENSIONE VASCA cm DIMENSIONS CUVE cm	DIMENSIONI ESTERNE cm OUTSIDE DIMESIONS cm	DIMENSIONI IMBALLO cm PACKAGE DIMENSIONS cm
48 lt	43 Kg	45 Ø 30 h	49,5 80 86 h	57 85 103 h

SKV 50 MO _ 230 V

MONOFASE
MONOPHASE

	POTENZA - POWER	PESO - WEIGHT	RPM	COD.
SKV 50 MO	3 Hp / 2,2 KW	122 Kg	55/239 6/26	7010151050

MACCHINA CON INVERIONE DI MARCIA
MACHINE WITH REVERSE DIRECTION FUNCTION

SK LINE

Impastatrice a spirale con testa e vasca fissa

Spiral mixer with fixed top and bowl





Spaccapasta e spirale in acciaio INOX
Dough breaker and spiral in stainless steel



Pannello di controllo / Control panel

Caratteristiche

L'impastatrice a spirale è la macchina ideale per lavorare impasti per pizzerie, pasticcerie, panetterie. La particolare forma della spirale consente in pochi minuti di ottenere impasti perfettamente amalgamati.

- Vasca, spirale, spaccapasta in acciaio inox 304
- Disponibile in versione a 1 e 2 velocità sia monofase che trifase
- Trasmissione a catena con motoriduttore a bagno d'olio per riduzione della rumorosità
- Stop di emergenza attivato da sollevamento griglia
- Timer e ruote di serie
- **La versione 2V monofase ha l'inversione di marcia**

Disponibilità di motori con frequenza a 60HZ, certificati UL ed a 240V con spina inglese.

+ 9,5 cm



Ruote e timer di serie
Castors and timer included

Features

The spiral dough mixer is the ideal equipment for working doughs for pizzerias, pastries, bakeries. The particular shape of the spiral allows you in few minutes to get a perfectly mixed dough.

- Bowl, spiral, dough breaker in stainless steel 304
- Available with 1 and 2 speed both monophase and triphase
- Chain transmission with gearmotor in oil bath to reduce the operating noise
- Emergency stop activated by lifting the protection grid.
- Timer and wheels include
- **2V monophase version has reverse direction function**

Availability of motors with 60HZ frequency, UL certified and 240V with english plug.



Versione Trifase
Threephase version

SK 10

VOLUME VASCA BOWL VOLUME	CAPACITÀ CAPACITY	DIMENSIONE VASCA cm DIMENSIONS CUVE cm	DIMENSIONI ESTERNE cm OUTSIDE DIMENSIONS cm	DIMENSIONI IMBALLO cm PACKAGE DIMENSIONS cm
7 lt	6 Kg	24 Ø 16 h	29 45 51 h	39 52 70 h

SK 10 MO _ 230 V

MONOFASE
MONOPHASE

	POTENZA - POWER	PESO - WEIGHT	RPM		COD.
SK 10 MO	0.3 Hp / 0,22 KW	34 Kg	70	10	7010121010

SK 10 MO 2V _ 230 V

MONOFASE 2 VELOCITÀ
MONOPHASE 2 SPEED

	POTENZA - POWER	PESO - WEIGHT	RPM		COD.
SK 10 MO 2V	0.3 Hp / 0,22 KW	36 Kg	70/140	10/20	7010147010

MACCHINA CON INVERIONE DI MARCIA
MACHINE WITH REVERSE DIRECTION FUNCTION

SK 15

VOLUME VASCA BOWL VOLUME	CAPACITÀ CAPACITY	DIMENSIONE VASCA cm DIMENSIONS CUVE cm	DIMENSIONI ESTERNE cm OUTSIDE DIMENSIONS cm	DIMENSIONI IMBALLO cm PACKAGE DIMENSIONS cm
16 lt	12 Kg	32 Ø 21 h	40 63 67 h	45 77 84 h

SK 15 TR _ 400 V

TRIFASE
THREEPHASE

SK 15 MO _ 230 V

MONOFASE
MONOPHASE

	POTENZA - POWER	PESO - WEIGHT	RPM		COD.
SK 15 TR	0.75 Hp / 0,55 KW	67 Kg	85	10	7010131015
SK 15 MO	0.75 Hp / 0,55 KW	68 Kg	85	10	7010121015
SK 15 TR 2V	1/1.5 Hp / 0,75/1.1 KW	73,5 Kg	85/170	10/20	7010141015

SK 15 TR 2V _ 400 V

TRIFASE 2 VELOCITÀ
THREEPHASE 2 SPEED

SK 15 MO 2V _ 230 V

MONOFASE 2 VELOCITÀ
MONOPHASE 2 SPEED

	POTENZA - POWER	PESO - WEIGHT	RPM		COD.
SK 15 MO 2V	1 Hp / 0,75 KW	71 Kg	85/170	10/20	7010147015

MACCHINA CON INVERIONE DI MARCIA
MACHINE WITH REVERSE DIRECTION FUNCTION

SK 20

VOLUME VASCA BOWL VOLUME	CAPACITÀ CAPACITY	DIMENSIONE VASCA cm DIMENSIONS CUVE cm	DIMENSIONI ESTERNE cm OUTSIDE DIMENSIONS cm	DIMENSIONI IMBALLO cm PACKAGE DIMENSIONS cm
21 lt	17 Kg	36 Ø 21 h	40 63 67 h	45 77 84 h

SK 20 TR _ 400 V

TRIFASE
THREEPHASE

SK 20 MO _ 230 V

MONOFASE
MONOPHASE

	POTENZA - POWER	PESO - WEIGHT	RPM		COD.
SK 20 TR	1 Hp / 0,75 KW	68 Kg	85	10	7010131020
SK 20 MO	1 Hp / 0,75 KW	69 Kg	85	10	7010121020
SK 20 TR 2V	1/1.5 Hp / 0,75/1.1 KW	74,5 Kg	85/170	10/20	7010141020

SK 20 TR 2V _ 400 V

TRIFASE 2 VELOCITÀ
THREEPHASE 2 SPEED

SK 20 MO 2V _ 230 V

MONOFASE 2 VELOCITÀ
MONOPHASE 2 SPEED

	POTENZA - POWER	PESO - WEIGHT	RPM		COD.
SK 20 MO 2V	1 Hp / 0,75 KW	72 Kg	85/170	10/20	7010147020

MACCHINA CON INVERIONE DI MARCIA
MACHINE WITH REVERSE DIRECTION FUNCTION

SK 30

VOLUME VASCA BOWL VOLUME	CAPACITÀ CAPACITY	DIMENSIONE VASCA cm DIMENSIONS CUVE cm	DIMENSIONI ESTERNE cm OUTSIDE DIMENSIONS cm	DIMENSIONI IMBALLO cm PACKAGE DIMENSIONS cm
32 lt	25 Kg	40 Ø 26 h	44 68 75 h	51 79 93 h

SK 30 TR _ 400 V

TRIFASE
THREEPHASE

SK 30 MO _ 230 V

MONOFASE
MONOPHASE

	POTENZA - POWER	PESO - WEIGHT	RPM		COD.
SK 30 TR	1,5 Hp / 1,1 KW	94 Kg	92	10	7010131030
SK 30 MO	1,5 Hp / 1,1 KW	95 Kg	92	10	7010121030
SK 30 TR 2V	1,7/2,5 Hp / 1,25/1,8 KW	97,5 Kg	92/184	10/20	7010141030

SK 30 TR 2V _ 400 V

TRIFASE 2 VELOCITÀ
THREEPHASE 2 SPEED

SK 30 MO 2V _ 230 V

MONOFASE 2 VELOCITÀ
MONOPHASE 2 SPEED

	POTENZA - POWER	PESO - WEIGHT	RPM		COD.
SK 30 MO 2V	1,5 Hp / 1,1 KW	82 Kg	92/184	10/20	7010147030

MACCHINA CON INVERIONE DI MARCIA
MACHINE WITH REVERSE DIRECTION FUNCTION

SK 40

VOLUME VASCA BOWL VOLUME	CAPACITÀ CAPACITY	DIMENSIONE VASCA cm DIMENSIONS CUVE cm	DIMENSIONI ESTERNE cm OUTSIDE DIMENSIONS cm	DIMENSIONI IMBALLO cm PACKAGE DIMENSIONS cm
41 lt	36 Kg	45 Ø 26 h	49,5 80 77 h	57 85 94 h

SK 40 TR _ 400 V

TRIFASE
THREEPHASE

SK 40 MO _ 230 V

MONOFASE
MONOPHASE

	POTENZA - POWER	PESO - WEIGHT	RPM		COD.
SK 40 TR	1,5 Hp / 1,1 KW	103,5 Kg	92	10	7010131040
SK 40 MO	1,5 Hp / 1,1 KW	96 Kg	92	10	7010121040
SK 40 TR 2V	1,7/2,5 Hp / 1,25/1,8 KW	107 Kg	92/184	10/20	7010141040

SK 40 TR 2V _ 400 V

TRIFASE 2 VELOCITÀ
THREEPHASE 2 SPEED

SK 40 MO 2V _ 230 V

MONOFASE 2 VELOCITÀ
MONOPHASE 2 SPEED

	POTENZA - POWER	PESO - WEIGHT	RPM		COD.
SK 40 MO 2V	3 Hp / 2,2 KW	109 Kg	92/184	10/20	7010147040

MACCHINA CON INVERIONE DI MARCIA
MACHINE WITH REVERSE DIRECTION FUNCTION

SK 50

VOLUME VASCA BOWL VOLUME	CAPACITÀ CAPACITY	DIMENSIONE VASCA cm DIMENSIONS CUVE cm	DIMENSIONI ESTERNE cm OUTSIDE DIMENSIONS cm	DIMENSIONI IMBALLO cm PACKAGE DIMENSIONS cm
48 lt	43 Kg	45 Ø 30 h	49,5 80 77 h	57 85 94 h

SK 50 TR _ 400 V

TRIFASE
THREEPHASE

SK 50 MO _ 230 V

MONOFASE
MONOPHASE

	POTENZA - POWER	PESO - WEIGHT	RPM		COD.
SK 50 TR	2 Hp / 1,5 KW	107,5 Kg	92	10	7010131050
SK 50 MO	2 Hp / 1,5 KW	109 Kg	92	10	7010121050
SK 50 TR 2V	2/3 Hp / 1,5/2,2 KW	110,5 Kg	92/184	10/20	7010141050

SK 50 TR 2V _ 400 V

TRIFASE 2 VELOCITÀ
THREEPHASE 2 SPEED

SK 50 MO 2V _ 230 V

MONOFASE 2 VELOCITÀ
MONOPHASE 2 SPEED

	POTENZA - POWER	PESO - WEIGHT	RPM		COD.
SK 50 MO 2V	3 Hp / 2,2 KW	118 Kg	92/184	10/20	7010147050

MACCHINA CON INVERIONE DI MARCIA
MACHINE WITH REVERSE DIRECTION FUNCTION

RTS LINE

Impastatrice a spirale con testa ribaltabile e vasca estraibile

Spiral mixer with lifting top and extractable bowl





Maniglia di apertura ergonomica / Ergonomic handle



Sistema di apertura e **chiusura rapida Easy-Up** della testa
Easy-Up system for fast opening and closing of the head

Caratteristiche

- Vasca, spirale, spaccapasta in acciaio inox 304
- Disponibile in versione a 1 e 2 velocità sia monofase che trifase
- Trasmissione a catena con motoriduttore a bagno d'olio per riduzione della rumorosità
- Stop di emergenza attivato da sollevamento griglia
- Testa ribaltabile con pistone a gas per un sollevamento controllato e sicuro
- Vasca rimovibile grazie al speciale sistema di bloccaggio rapido certificato
- Timer e ruote di serie
- **La versione 2V monofase ha l'inversione di marcia**

Disponibilità di motori con frequenza a 60HZ, certificati UL ed a 240V con spina inglese.

Features

- Bowl, spiral, dough breaker in stainless steel 304
- Available with 1 and 2 speed both monophase and triphase
- Chain transmission with gearmotor in oil bath to reduce the operating noise.
- Emergency stop activated by lifting the protection grid.
- Lifting head with gas activated piston for a safe and soft lifting.
- Extractable bowl with certified smart screw – unscrew system
- Timer and wheels included
- **2V monophase version has reverse direction function**

Availability of motors with 60HZ frequency, UL certified and 240V with english plug.

RTS 20

VOLUME VASCA BOWL VOLUME	CAPACITÀ CAPACITY	DIMENSIONE VASCA cm DIMENSIONS CUVE cm	DIMENSIONI ESTERNE cm OUTSIDE DIMESIONS cm	DIMENSIONI IMBALLO cm PACKAGE DIMENSIONS cm
21 lt	17 Kg	36 Ø 21 h	39 67 67 h	45 77 84 h

RTS 20 TR _ 400 V

TRIFASE
THREEPHASE

RTS 20 MO _ 230 V

MONOFASE
MONOPHASE

	POTENZA - POWER	PESO - WEIGHT	RPM		COD.
RTS 20 TR	1 Hp / 0,75 KW	80 Kg	85	10	7010132020
RTS 20 MO	1 Hp / 0,75 KW	80 Kg	85	10	7010122020
RTS 20 TR 2V	1/1,5 Hp / 0,75/1,1 KW	82 Kg	85/170	10/20	7010142020

RTS 20 TR 2V _ 400 V

TRIFASE 2 VELOCITÀ
THREEPHASE 2 SPEED

RTS 20 MO 2V _ 230 V

MONOFASE 2 VELOCITÀ
MONOPHASE 2 SPEED

	POTENZA - POWER	PESO - WEIGHT	RPM		COD.
RTS 20 MO 2V	1 Hp / 0,75 KW	82 Kg	85/170	10/20	7010162020

MACCHINA CON INVERIONE DI MARCIA
MACHINE WITH REVERSE DIRECTION FUNCTION

RTS 30

VOLUME VASCA BOWL VOLUME	CAPACITÀ CAPACITY	DIMENSIONE VASCA cm DIMENSIONS CUVE cm	DIMENSIONI ESTERNE cm OUTSIDE DIMESIONS cm	DIMENSIONI IMBALLO cm PACKAGE DIMENSIONS cm
21 lt	25 Kg	40 Ø 26 h	47 74 75 h	51 79 93 h

RTS30 TR _ 400 V

TRIFASE
THREEPHASE

RTS 30 MO _ 230 V

MONOFASE
MONOPHASE

	POTENZA - POWER	PESO - WEIGHT	RPM		COD.
RTS 30 TR	1,5 Hp / 1,1 KW	99 Kg	92	10	7010132030
RTS 30 MO	1,5 Hp / 1,1 KW	99 Kg	92	10	7010122030
RTS 30 TR 2V	1,7/2,5 Hp / 1,25/1,8 KW	99 Kg	92/184	10/20	7010142030

RTS 30 TR 2V _ 400 V

TRIFASE 2 VELOCITÀ
THREEPHASE 2 SPEED

RTS 30 MO 2V _ 230 V

MONOFASE 2 VELOCITÀ
MONOPHASE 2 SPEED

	POTENZA - POWER	PESO - WEIGHT	RPM		COD.
RTS 30 MO 2V	2 Hp / 1,5 KW	99 Kg	92/184	10/20	7010162030

MACCHINA CON INVERIONE DI MARCIA
MACHINE WITH REVERSE DIRECTION FUNCTION

RTS 40

VOLUME VASCA BOWL VOLUME	CAPACITÀ CAPACITY	DIMENSIONE VASCA cm DIMENSIONS CUVE cm	DIMENSIONI ESTERNE cm OUTSIDE DIMENSIONS cm	DIMENSIONI IMBALLO cm PACKAGE DIMENSIONS cm
41 lt	36 Kg	45 Ø 26 h	48 81 77 h	57 85 94 h

RTS 40 TR _ 400 V

TRIFASE
THREEPHASE

RTS 40 TR 2V _ 400 V

TRIFASE 2 VELOCITÀ
THREEPHASE 2 SPEED

RTS 40 MO _ 230 V

MONOFASE
MONOPHASE

RTS 40 MO 2V _ 230 V

MONOFASE 2 VELOCITÀ
MONOPHASE 2 SPEED

	POTENZA - POWER	PESO - WEIGHT	RPM		COD.
RTS 40 TR	1,5 Hp / 1,1 KW	114 Kg	92	10	7010132040
RTS 40 MO	1,5 Hp / 1,1 KW	114 Kg	92	10	7010122040
RTS 40 TR 2V	1,7/2,5 Hp / 1,25/1,8 KW	114 Kg	92/184	10/20	7010142040

	POTENZA - POWER	PESO - WEIGHT	RPM		COD.
RTS 40 MO 2V	3 Hp / 2,2 KW	114 Kg	92/184	10/20	7010162040

MACCHINA CON INVERIONE DI MARCIA
MACHINE WITH REVERSE DIRECTION FUNCTION

RTS 50

VOLUME VASCA BOWL VOLUME	CAPACITÀ CAPACITY	DIMENSIONE VASCA cm DIMENSIONS CUVE cm	DIMENSIONI ESTERNE cm OUTSIDE DIMENSIONS cm	DIMENSIONI IMBALLO cm PACKAGE DIMENSIONS cm
48 lt	43 Kg	45 Ø 30 h	48 81 77 h	57 85 94 h

RTS 50 TR _ 400 V

TRIFASE
THREEPHASE

RTS 50 TR 2V _ 400 V

TRIFASE 2 VELOCITÀ
THREEPHASE 2 SPEED

RTS 50 MO _ 230 V

MONOFASE
MONOPHASE

RTS 50 MO 2V _ 230 V

MONOFASE 2 VELOCITÀ
MONOPHASE 2 SPEED

	POTENZA - POWER	PESO - WEIGHT	RPM		COD.
RTS 50 TR	2 Hp / 1,5 KW	136 Kg	92	10	7010132050
RTS 50 MO	2 Hp / 1,5 KW	136 Kg	92	10	7010122050
RTS 50 TR 2V	2/3 Hp / 1,5/2,2 KW	136 Kg	92/184	10/20	7010142050

	POTENZA - POWER	PESO - WEIGHT	RPM		COD.
RTS 50 MO 2V	3 Hp / 2,2 KW	136 Kg	92/184	10/20	7010162050

MACCHINA CON INVERIONE DI MARCIA
MACHINE WITH REVERSE DIRECTION FUNCTION

RTF LINE

Impastatrice a spirale con testa ribaltabile e vasca fissa

Spiral mixer with lifting top and fixed bowl





Maniglia di apertura ergonomica / Ergonomic handle



Sistema di apertura e **chiusura rapida Easy-Up** della testa
Easy-Up system for fast opening and closing of the head

Caratteristiche

- Vasca, spirale, spaccapasta in acciaio inox 304
- Disponibile in versione a 1 e 2 velocità sia monofase che trifase
- Trasmissione a catena con motoriduttore a bagno d'olio per riduzione della rumorosità
- Stop di emergenza attivato da sollevamento griglia
- Testa ribaltabile con pistone a gas per un sollevamento controllato e sicuro
- Timer e ruote di serie

Features

- Bowl, spiral, dough breaker in stainless steel 304
- Available with 1 and 2 speed both monophase and triphase
- Chain transmission with gearmotor in oil bath to reduce the operating noise.
- Emergency stop activated by lifting the protection grid.
- Lifting head with gas activated piston for a safe and soft lifting.
- Timer and wheels included

Disponibilità di motori con frequenza a 60HZ, certificati UL ed a 240V con spina inglese.

Availability of motors with 60HZ frequency, UL certified and 240V with english plug.

+ 9,5 cm



Ruote e timer di serie
Castors and timer included



Versione Trifase
Threephase version

RTF 20

VOLUME VASCA BOWL VOLUME	CAPACITÀ CAPACITY	DIMENSIONE VASCA cm DIMENSIONS CUVE cm	DIMENSIONI ESTERNE cm OUTSIDE DIMENSIONS cm	DIMENSIONI IMBALLO cm PACKAGE DIMENSIONS cm
21 lt	17 Kg	36 Ø 21 h	39 67 67 h	45 77 84 h

RTF 20 TR _ 400 V

TRIFASE
THREEPHASE

RTF 20 MO _ 230 V

MONOFASE
MONOPHASE

	POTENZA - POWER	PESO - WEIGHT	RPM		COD.
RTF 20 TR	1 Hp / 0,75 KW	71 Kg	85	10	7010133020
RTF 20 MO	1 Hp / 0,75 KW	71 Kg	85	10	7010123020
RTF 20 TR 2V	1/1,5 Hp / 0,75/1,1 KW	71 Kg	85/170	10/20	7010143020

RTF 20 TR 2V _ 400 V

TRIFASE 2 VELOCITÀ
THREEPHASE 2 SPEED

RTF 30

VOLUME VASCA BOWL VOLUME	CAPACITÀ CAPACITY	DIMENSIONE VASCA cm DIMENSIONS CUVE cm	DIMENSIONI ESTERNE cm OUTSIDE DIMENSIONS cm	DIMENSIONI IMBALLO cm PACKAGE DIMENSIONS cm
32 lt	25 Kg	40 Ø 26 h	43 74 75 h	51 79 93 h

RTF 30 TR _ 400 V

TRIFASE
THREEPHASE

RTF 30 MO _ 230 V

MONOFASE
MONOPHASE

	POTENZA - POWER	PESO - WEIGHT	RPM		COD.
RTF 30 TR	1,5 Hp / 1,1 KW	99 Kg	92	10	7010133130
RTF 30 MO	1,5 Hp / 1,1 KW	99 Kg	92	10	7010123130
RTF 30 TR 2V	1,7/2,5 Hp / 1,25/1,8 KW	99 Kg	92/184	10/20	7010143130

RTF 30 TR 2V _ 400 V

TRIFASE 2 VELOCITÀ
THREEPHASE 2 SPEED

RTF 40

VOLUME VASCA BOWL VOLUME	CAPACITÀ CAPACITY	DIMENSIONE VASCA cm DIMENSIONS CUVE cm	DIMENSIONI ESTERNE cm OUTSIDE DIMENSIONS cm	DIMENSIONI IMBALLO cm PACKAGE DIMENSIONS cm
41 lt	36 Kg	45 Ø 26 h	48 81 77 h	57 85 94 h

RTF 40 TR _ 400 V

TRIFASE
THREEPHASE

RTF 40 TR 2V _ 400 V

TRIFASE 2 VELOCITÀ
THREEPHASE 2 SPEED

RTF 40 MO _ 230 V

MONOFASE
MONOPHASE

	POTENZA - POWER	PESO - WEIGHT	RPM		COD.
RTF 40 TR	1,5 Hp / 1,1 KW	114 Kg	92	10	7010133040
RTF 40 MO	1,5 Hp / 1,1 KW	114 Kg	92	10	7010123040
RTF 40 TR 2V	1,7/2,5 Hp / 1,25/1,8 KW	114 Kg	92/184	10/20	7010143040

RTF 50

VOLUME VASCA BOWL VOLUME	CAPACITÀ CAPACITY	DIMENSIONE VASCA cm DIMENSIONS CUVE cm	DIMENSIONI ESTERNE cm OUTSIDE DIMENSIONS cm	DIMENSIONI IMBALLO cm PACKAGE DIMENSIONS cm
48 lt	43 Kg	45 Ø 30 h	48 81 77 h	57 85 94 h

RTF 50 TR _ 400 V

TRIFASE
THREEPHASE

RTF 50 TR 2V _ 400 V

TRIFASE 2 VELOCITÀ
THREEPHASE 2 SPEED

RTF 50 MO _ 230 V

MONOFASE
MONOPHASE

	POTENZA - POWER	PESO - WEIGHT	RPM		COD.
RTF 50 TR	2 Hp / 1,5 KW	136 Kg	92	10	7010133050
RTF 50 MO	2 Hp / 1,5 KW	136 Kg	92	10	7010123050
RTF 50 TR 2V	2/3 Hp / 1,5/2,2 KW	136 Kg	92/184	10/20	7010143050

FR LINE

Impastatrice a forcella

Fork kneading machine



Caratteristiche

Consente di amalgamare omogeneamente in breve tempo piccoli e grandi volumi d'impasto di svariati tipi, anche quelli più duri. La delicata rotazione dell'utensile a forcella permette un'ottima ossigenazione dell'impasto e non lo riscalda, rendendo così più friabile il prodotto finito.

Features

It allows to amalgamate homogeneously both small or large quantities of dough (even the harder types) in a short time. The delicate rotation of the fork utensil permits a perfect oxygenation of the dough and it doesn't warm it up; all this results in a more crumbly end product.

Dati tecnici:

Costruzioni in acciaio verniciato bianco. Vasca, coperchio e utensile a forcella in acciaio INOX AISI 304.

Technical Data

The mixer has a solid steel painted body and the bowl, the fork tool and the lid are in stainless steel INOX AISI 304.

Optional:

Cavalletto con ruote H 40 cm - COD. 7010100003
Carrello con ruote H 10 cm - COD. 7010100004
Temporizzatore FR - COD. 7010100005

Optional

Stand with wheels H 40 cm - COD. 7010100003
Trolley with wheels H 10 cm - COD. 7010100004
Timer FR - COD. 7010100005



FR 30

VOLUME VASCA BOWL VOLUME	CAPACITÀ CAPACITY	POTENZA POWER	PESO WEIGHT	DIMENSIONI ESTERNE cm OUTSIDE DIMENSIONS cm	DIMENSIONI IMBALLO cm PACKAGE DIMENSIONS cm
35 lt	30 Kg	0,75 Kw	140 Kg	100 65 61 h	107 67 79 h

FR 30 TR _ 400 V

TRIFASE
THREEPHASE

FR 30 MO _ 230 V

MONOFASE
MONOPHASE

FR 30 TR 2V _ 400 V

TRIFASE
THREEPHASE

	COD.
FR 30 TR	7010133030
FR 30 MO	7010123030
FR 30 TR 2V	7010143030

FP LINE

Impastatrice planetaria da banco

Countertop rotary kneader



Caratteristiche

STRUTTURA VERNICIATA ANTIGRAFFIO. VASCA, UNCINO, SPATOLA E FRUSTA IN ACCIAIO INOX AISI 304

Testa sollevabile. Coperchio vasca in policarbonato trasparente. Utensili e vasca a sgancio rapido. Variatore elettronico di velocità con trasmissione a cinghia ed ingranaggi. In dotazione: Vasca, uncino, spatola e frusta.

Features

SCRATCH RESISTANT PAINTED BODY. BOWL, HOOK, BEATER AND WHISK IN AISI 304 STAINLESS STEEL.

It allows to amalgamate homogeneously both small or large quantities of dough (even the harder types) in a short time. The delicate rotation of the fork utensil permits a perfect oxygenation of the dough and it doesn't warm it up; all this results in a more crumbly end product.



FP 105 / 107 / 110

	VOLUME VASCA BOWL VOLUME	POTENZA POWER	VELOCITÀ SPEED	PESO WEIGHT	DIMENSIONI ESTERNE OUTSIDE DIMENSIONS	DIMENSIONI IMBALLO PACKAGE DIMENSIONS	COD
FP 105	5 lt	220-240V 50-60Hz 0,50KW	0 - 302 rpm	13 Kg	38 24 40 h	45 31 44 h	7010124005
FP 107	7,5 lt	220-240V 50-60Hz 0,50KW	0 - 302 rpm	15 Kg	38 24 42 h	45 31 47 h	7010124007
FP 110	10 lt	220V 50-60Hz 0,50KW	0 - 302 rpm	18 Kg	38 24 44,5 h	45 31 51 h	7010124010

Trasmissione a cinghia - Belt transmission

IN DOTAZIONE - INCLUDED



SPATOLA
BEATER



FRUSTA
WHISK



UNCINO
HOOK



VASCA
BOWL

KP LINE

Impastatrice planetaria

Rotary kneader



Caratteristiche

STRUTTURA VERNICIATA ANTIGRAFFIO. VASCA, UNCINO, SPATOLA E FRUSTA IN ACCIAIO INOX AISI 304

Vasca sganciabile, griglia in acciaio, selettore con 3 velocità differenti, bottone di stop.

Features

SCRATCH RESISTANT PAINTED BODY. BOWL, HOOK, BEATER AND WHISK IN AISI 304 STAINLESS STEEL.

Removable bowl, grid in steel, selector with 3 different speed levels, stop button.

Preparazione
impasto



KP 110 /120 / 130



KP 140

	VOLUME VASCA BOWL VOLUME	POTENZA POWER	VELOCITÀ SPEED	PESO WEIGHT	DIMENSIONI ESTERNE OUTSIDE DIMENSIONS	DIMENSIONI IMBALLO PACKAGE DIMENSIONS	COD
KP 110	10 lt	230V - 1-50Hz 0,45KW	3 SPEED 113/184/341 rpm	55 Kg	45 43 61 h	54 48 75 h	7010125010
KP 120	20 lt	230V - 1-50Hz 1,10KW	3 SPEED 108/161/382 rpm	81 Kg	53 50 78 h	63 57 92 h	7010125020
KP 130	30 lt	3~380V - 1-50Hz 1,10KW	3 SPEED 108/161/382 rpm	85 Kg	55 51 85 h	63 57 99 h	7010135030
KP 140	40 lt	3~380V - 1-50Hz 2,20KW	3 SPEED 84/151/270 rpm	149 Kg	64 53 100 h	73 64 116 h	7010135040

IN DOTAZIONE - INCLUDED



SPATOLA
BEATER



FRUSTA
WHISK



UNCINO
HOOK



VASCA
BOWL





Lavorazione
Impasto

Lavorazione Impasto Kneading Processing

COMBI LINE POR - RM

Spezzatrice e arrotondatrice
Divider and rounding machine





POR 900

SPEZZATRICI | DIVIDERS MACHINES

	PRODUZIONE ORARIA OUTPUT/HOUR	CAPACITÀ VASCA BOWL CAPACITY	PORZIONE PASTA DOUGH PORTION	POTENZA POWER	DIMENSIONI DIMENSIONS	PESO WEIGHT	COD
POR 300	340 (250 gr-r)/H	30 Kg	50 ÷ 300 gr	0,93 KW - 1,20 HP - 400V	51X83X53	74 Kg	718023PR30
POR 900	340 (250 gr-r)/H	30 Kg	50 ÷ 3x300	0,93 KW - 1,20 HP - 400V	51X83X66	84 Kg	718023PR90

Porzione pasta per impasto pizza tradizionale - Dough portion for traditional pizza dough

Diametro boccola per - Bush diameter for: POR 300 - POR 900

gr/r	50 ÷ 90	80 ÷ 130	120 ÷ 180	170 ÷ 230	220 ÷ 300
∅ cm	4	4,5	5	5,5	6



RM 900

ARROTONDATRICI | ROUNDING MACHINES

	PORZIONE PASTA DOUGH PORTION	POTENZA POWER	DIMENSIONI DIMENSIONS	PESO WEIGHT	COD
RM 300 MO	50 ÷ 300 gr	0,37 KW - 0,50 HP - 230V	44X58X82	48 Kg	718011RM30
RM 900 MO	50 ÷ 8/900 gr	0,37 KW - 0,50 HP - 230V	50X62X88	68 Kg	718011RM90
RM 300 TR	50 ÷ 300 gr	0,37 KW - 0,50 HP - 400V	44X58X82	48 Kg	718013RM30
RM 900 TR	50 ÷ 8/900 gr	0,37 KW - 0,50 HP - 400V	50X62X88	68 Kg	718013RM90

SPEZZATRICI E ARROTONDATRICI | DIVIDERS AND ROUNDING MACHINES



Lavorazione
Impasto

COMBI 300

POR 300 + SUPP-PORZ 300 + RM 300
per palline di max 300 gr
for max 300 gr balls

COMBI 900

POR 900 + SUPP-PORZ 900 + RM 900
per palline di max 800/900 gr
for max 8/900 gr balls

	PRODUZIONE ORARIA OUTPUT/HOUR	PORZIONE PASTA DOUGH PORTION	POTENZA POWER	DIMENSIONI DIMENSIONS	PESO WEIGHT	COD
COMBI 300	340 (250 gr-r)/H	50 ÷ 300	1,3 KW - 1,7 HP - 230/400V	66X88X149	151 Kg	718033CB30
COMBI 900	340 (250 gr-r)/H	50 ÷ 8x900	1,3 KW - 1,7 HP - 230/400V	66X88X162	181 Kg	718033CB90

SUPPORTO | STAND

OPTIONAL

Supporto in acciaio inox
Stand in stainless steel

	DIMENSIONI DIMENSIONS	PESO WEIGHT	COD
SUPP-POR 300	66x88x96	29 Kg	718040SP30
SUPP-POR 900	66x88x96	32 Kg	718040SP90



FORM LINE

Formatrice a caldo
Hot shaping machine



Caratteristiche

Semplicità di regolazione e di utilizzo, disponibilità di piatti lisci o con bordo da 33 o 45 cm di diametro, facilità di pulizia, riscaldamento veloce e massima sicurezza.

Le nuove tecniche utilizzate rendono le nostre formatrici:

Affidabili e precise: la regolazione del piatto inferiore diventa più precisa, anche nel lungo andare, grazie al nuovo sistema di automazione a motore auto-frenante. Precisione millimetrica, garantendo uno schiacciamento sicuro anche dopo migliaia di cicli.

Allacciamento elettrico semplificato: il senso di marcia del motore non è più un problema.

Sostituzione rapida dei piatti teflonati: i perni filettati al corpo riscaldante sono la nostra chiave per una semplice e rapida sostituzione dei piatti.

Features

Ease of adjustment and use, smooth plates or plates with a diameter of either 33 or 45 cm, easy cleaning, fast heating and maximum safety.

The new techniques we use make our pizza presses:

Reliable and precise: adjusting the lower plate becomes more precise, even in the long run, thanks to the new self-braking motor automation system. The utmost precision, which ensures safe crushing even after thousands of cycles.

Simplified electrical connection: the motor's rotating direction is no longer a problem.

Quick replacement of the Teflon plates: the threaded pins on the heating body are our key to a simple and quick replacement of the plates.

FORM RI 33 - 45

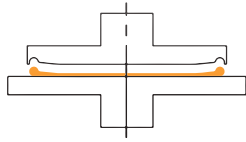

Versione per pizza con bordo
Version for pizza with edge

FORM RI 33L - 45L

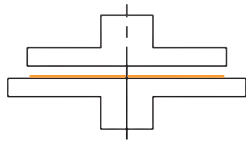

Versione per pizza senza bordo
Version for pizza without edge

		PESO PASTA DOUGH WEIGHT	DIAMETRO PIZZA PIZZA DIAMETER	ALIMENTAZIONE POWER	POTENZA MOTORE MOTOR POWER	DIMENSIONI DIMENSIONS	PESO WEIGHT	COD
	FORM RI 33	130/250 gr	33 mm	6,37 hp / 400 V	4,75 KW	47X59X83	96 Kg	719013RI33
	FORM RI 45	250/500 gr	45 mm	8,2 hp / 400 V	6,1 KW	63X67X89	127 Kg	719013RI45
	FORM RI 33L	130/250 gr	33 mm	6,37 hp / 400 V	4,75 KW	47X59X83	96 Kg	719013RI33L
	FORM RI 45L	250/500 gr	45 mm	8,2 hp / 400 V	6,1 KW	63X67X89	127 Kg	719013RI45L

ALIMENTAZIONE MONOFASE | SINGLE-PHASE

DISPONIBILITÀ SU RICHIESTA AD ALIMENTAZIONE MONOFASE
AVAILABILITY ON REQUEST FOR SINGLE-PHASE POWER SUPPLY

OPTIONAL

Supporto in acciaio inox
Stand in stainless steel

Set di Ruote
Wheels

DIMENSIONI DIMENSIONS	PESO WEIGHT	COD
62x66x73	14 Kg	7190300SF0
+ 11	/	7190300RF0



SPR LINE

Dilaminatrice / Stendipizza

Pizza dough roller



Caratteristiche

- Struttura in acciaio inox
- Motore elettrico dotato di ventola di raffreddamento per lunghe sessioni di lavoro
- Regolazione spessore impasto (da 0,5 a 4mm)
- Lavorazione dell'impasto a freddo per non alterare e caratteristiche dell'impasto

Features

- Stainless steel structure
- Electric motor equipped with cooling fan for long working term
- Dough thickness regulation (0,5 - 4mm)
- Cold mixing to avoid damaging the dough characteristics



SPR UNO



SPR



SPR PA

Lavorazione Impasto

	PESO PASTA DOUGH WEIGHT	DIAMETRO PIZZA PIZZA DIAMETER	ALIMENTAZIONE POWER	POTENZA MOTORE MOTOR POWER	DIMENSIONI DIMENSIONS	PESO WEIGHT	COD
SPR 30 UNO	80/210 gr	140/300 mm	230V/ 1 hp / 50 Hz	0,37 KW	440x355x355h	21 Kg	70301210301
SPR 50 UNO	210/700 gr	260/450 mm	230V/ 1 hp / 50 Hz	0,37 KW	650x355x355h	25 Kg	70301210501
SPR 30	80/210 gr	140/300 mm	230V/ 1 hp / 50 Hz	0,37 KW	440x365x640h	27 Kg	7030121030
SPR 40	210/700 gr	260/400 mm	230V/ 1 hp / 50 Hz	0,37 KW	550x365x750h	34 Kg	7030121040
SPR 40 PA	210/900 gr	260/400 mm	230V/ 1 hp / 50 Hz	0,37 KW	550x365x750h	34 Kg	70301210401
SPR 50 PA	210/900 gr	260/450 mm	230V/ 1 hp / 50 Hz	0,37 KW	650x500x700h	41 Kg	7030121050

PEDALE ELETTRICO - ELECTRIC FOOTPEDAL

Optional in tutti i modelli - Optional in all models



CODICE - CODE 7030111001

- Consigliamo sempre di acquistare e utilizzare il pedale di avviamento, per ridurre inutili consumi elettrici e allungare la vita del prodotto, diminuendone i tempi di funzionamento a vuoto.
- We always recommend to buy and use the footswitch start, to reduce unnecessary energy consumption and make your device last longer, reducing the time it's turned on without working.





Taglio

Taglio Cutting

TITANIUM LINE

Tagliaverdure, grattugia e tagliamozzarella

Vegetable cutter, grater and mozzarella cutter



INTERRUTTORE
A BASSA TENSIONE
12 VOLT



Caratteristiche

Macchina professionale per tagliare, affettare, cubettare, fare listelli, grattugiare, sfilacciare verdure, frutta, ortaggi, pane, formaggio, cioccolato e molti altri prodotti

- Struttura in acciaio inox e top in alluminio pressofuso
- Coperchio ribaltabile ed estraibile
- Ampia scelta di dischi intercambiabili per molteplici tipi di taglio e lavorazione
- Puleggia in metallo e cinghia rinforzata
- Doppia bocca di introduzione
- 2 Stop di emergenza: il primo attivato da apertura manico, con riavvio automatico; il secondo attivato da apertura coperchio con riavvio manuale richiesto.

Features

Professional machine for cutting, slicing, cube and stick cutting, mincing and shredding, vegetables, fruit, bread, cheese, chocolate and many products.

- Stainless steel base structure
- Lifting and removable cover
- And die-cast aluminium top
- Wide choice of interchangeable discs for different types of cut
- Metal pulley and reinforced belt
- Double introduction spots
- 2 Emergency stops: the first is activated by opening the handle, with automatic restart. The second is activated by opening the lid, with manual restart required.

TITANIUM MO / TR

TITANIUM MO

MONOFASE
MONOPHASE

TITANIUM TR

TRIFASE
THREEPHASE

PRODUZIONE H OUTPUT H	DIMENSIONI DIMENSIONS	PESO WEIGHT
200 kg/h	261x604x522	22 kg

	POTENZA POWER	COD.
TITANIUM MO	230V - 50HZ - 0,37 KW hp0,50	7040121205
TITANIUM TR	400V - 50HZ - 0,37 KW hp0,50	7040131205



TITANIUM + KIT 1 - DISCS DF2 DTV - DT10

TITANIUM + KIT 2 - DISCS DF2 - DTV DT10 - DQ04 - DT07

TITANIUM

PRODUZIONE H OUTPUT H	POTENZA POWER	DIMENSIONI DIMENSIONS
200 kg/h	230/400V - 50HZ - 0,37 KW hp0,50	261x604x522

	DISCHI PER TAGLIO SLICING DISCS	PESO WEIGHT	COD.
TITANIUM + KIT 1	DF2 - DTV - DT10	25 kg	7040121235
TITANIUM + KIT 2	DF2 - DTV - DT10 - DQ04 - DT07	27 kg	7040121255

GOLD LINE

Tagliaverdure, grattugia e tagliamozzarella

Vegetable cutter, grater and mozzarella cutter



Caratteristiche

- Apparecchio per uso professionale, ideale per alberghi ristoranti e mense.
- Struttura in acciaio inox e top in alluminio pressofuso
 - Ampia scelta di dischi intercambiabili per molteplici tipi di taglio e lavorazione
 - Puleggia in metallo e cinghia rinforzata
 - Doppia bocca di introduzione
 - 2 Stop di emergenza: il primo attivato da apertura manico, con riavvio automatico; il secondo attivato da apertura coperchio con riavvio manuale richiesto

Features

- Professional benchtop food processor, designed for moderate to high volume use in larger restaurants and commercial kitchens.
- Stainless steel base structure
 - And die-cast aluminium top
 - Wide choice of interchangeable discs for different types of cut
 - Metal pulley and reinforced belt
 - Double introduction spots
 - 2 Emergency stops: the first is activated by opening the handle, with automatic restart. The second is activated by opening the lid, with manual restart required.

GOLD MO / TR

GOLD MO

MONOFASE
MONOPHASE

GOLD TR

TRIFASE
THREEPHASE

PRODUZIONE H OUTPUT H	DIMENSIONI DIMENSIONS	PESO WEIGHT
200 kg/h	280x490x530	18 kg

	POTENZA POWER	COD.
GOLD MO	230V - 50HZ - 0,58 kW	7040121305
GOLD TR	400V - 50HZ - 0,58 kW	7040131305



**GOLD + KIT 1 - DISCS DF2 - DTV
DT10**

**GOLD + KIT 2 - DISCS DF2-DTV-DT10
DQ04-DT07**

PRODUZIONE H OUTPUT H	POTENZA POWER	DIMENSIONI DIMENSIONS
200 kg/h	230/400V - 50HZ - 0,58 kW	280x490x530

	DISCHI PER TAGLIO SLICING DISCS	PESO WEIGHT	COD.
GOLD + KIT 1	DF2 - DTV - DT10	20 kg	7040121335
GOLD + KIT 2	DF2 - DTV - DT10 - DQ04 - DT07	25 kg	7040121355

Taglio

DISCHI PER TAGLIO - SLICING DISCS



	DF01	DF2	DF2,5N	DF04	DS04	DF04N
SPESSORE THICKNESS	1 mm	2 mm	2,5 mm	4 mm	4 mm	4 mm
COD.	7040100001I	7040100002I	7040100002N	7040100004I	7040100016I	7040100004N



	DF06	DF06N	DF08	DF10	DS10	DF14
SPESSORE THICKNESS	6 mm	6 mm	8 mm	10 mm	10 mm	14 mm
COD.	7040100006I	7040100006N	7040100008I	7040100010I	7040100017I	7040100014I

DISCHI PER LISTELLI RICURVI (TAGLIO A JULIENNE)
CURVED STICK CUTTING DISCS (JULIENNE CUTTING)



	DQ04	DQ06	DQ08	DQ10
SPESSORE THICKNESS	4 mm	6 mm	8 mm	10 mm
COD.	7040200004	7040200006	7040200008	7040200010

DISCHI PER TAGLIO A LISTELLI - STICK CUTTING DISCS - ZERHACKSCHEIBE
DISQUES POUR EFFILOCHER - DISCOS PARA TRITURAR



	PC06	PC08	PC10
SPESSORE THICKNESS	6 mm	8 mm	10 mm
COD.	7040400006	7040400008I	7040400010I

**DISCHI PER GRATTUGIARE
GRATING DISCS**



	DTV
SPESSORE THICKNESS	< 1 mm
COD.	70403000011

**DISCHI PER SFILACCIARE
SHREDDING DISCS**



	DT02	DT03	DT04	DT05	DT07	DT10
SPESSORE THICKNESS	2 mm	3 mm	4 mm	5 mm	7 mm	10 mm
COD.	70403000021	70403000031	70403000041	70403000111	70403000051	70403000121

DISCHI PER CUBETTARE - CUBE CUTTING DISCS



	PS08	PS10	PS14	PS20
SPESSORE THICKNESS	8 mm	10 mm	14 mm	20 mm
COD.	70403000071	704033000081	70403000101	70403000131

ATTENZIONE Per cubettare abbinare i dischi per affettare della medesima misura
ATTENTION To cube please combine the same size slicing discs

Taglio





Preparazione
Carne

Preparazione Carne

Meat Preparation

SL LINE

Affettatrice a gravità

Gravity feed slicer



Caratteristiche

Per piccole necessità produttive ed in particolare per il taglio di salumi, formaggi e verdure. CE USO DOMESTICO.

SL 220

SL 220S

	COD
SL 220S	7100111220S

SL 220S

AFFILATOIO FISSO
FIXED SHARPENER



LAMA BLADE	POTENZA POWER	CAPACITÀ TAGLIO OUTPUT PER HOUR	DIMENSIONI DIMENSIONS	PESO WEIGHT
220 mm	160 W	220x165 mm	360x440x330	10,2 KG

SL 250

SL 250S

	COD
SL 250S	7100111250S

SL 250S

AFFILATOIO FISSO
FIXED SHARPENER



LAMA BLADE	POTENZA POWER	CAPACITÀ TAGLIO OUTPUT PER HOUR	DIMENSIONI DIMENSIONS	PESO WEIGHT
250 mm	160 W	230x175 mm	440x530x355	14 KG

Caratteristiche

Per piccole attività, pizzerie, piccoli ristoranti, per il taglio di salumi, carni cotte, prosciutti cotti.

SL 300

SL 300S

	COD
SL 300S	7100111300S

LAMA BLADE	POTENZA POWER	CAPACITÀ TAGLIO OUTPUT PER HOUR	DIMENSIONI DIMENSIONS	PESO WEIGHT
300 mm	0,23 HP	180x250 mm	650x510x470	20 KG

Features

For small businesses, pizzerias, small restaurants, for cutting cold cuts, cooked meats, cooked hams.



Caratteristiche

Per medie attività, pizzerie, ristoranti, per prosciutto cotto, prosciutto crudo 6/7kg, tutti i tipi di affettati, carni crude, formaggi.

SL 350

SL 350S

	COD
SL 350S	7100111350S

LAMA BLADE	POTENZA POWER	CAPACITÀ TAGLIO OUTPUT PER HOUR	DIMENSIONI DIMENSIONS	PESO WEIGHT
350 mm	0,37 HP	200x250 mm	690x540x480	33 KG

Features

For medium activities, pizzerias, restaurants, for cooked ham, 6 / 7kg raw ham, all types of cold cuts, raw meats, cheeses.



Caratteristiche

Per grandi attività, pizzerie, ristoranti, grossi prosciutti cotti e crudi da 8-12 kg, tutti i tipi di salumi, e carni crude-formaggi.

Features

For large activities, pizzerias, restaurants, large cooked and raw hams of 8-12 kg, all types of meats, and raw meats-cheeses.

SL 350S SUPERIOR

SL 350S SUPERIOR

	COD
SL 350S SUPERIOR	7100111350SS



LAMA BLADE	POTENZA POWER	CAPACITÀ TAGLIO OUTPUT PER HOUR	DIMENSIONI DIMENSIONS	PESO WEIGHT
350 mm	0,5 HP	205x280 mm	790x580x570	44 KG

SL 370S SUPERIOR

SL 370S SUPERIOR

	COD
SL 370S SUPERIOR	7100111370SS



LAMA BLADE	POTENZA POWER	CAPACITÀ TAGLIO OUTPUT PER HOUR	DIMENSIONI DIMENSIONS	PESO WEIGHT
370 mm	0,5 HP	215x280 mm	790x580x570	45 KG

SLV LINE

Affettatrice verticale
Vertical slicer



Caratteristiche

Per piccole attività, pizzeria, piccola alimentazione, piccola cucina, piccoli salumi e formaggi - carrello universale.

Features

For small activities, pizzeria, small food, small kitchen, small meats and cheeses - universal trolley.

SLV 300S



SLV 300S - BC



SLV 300S - BS

LAMA BLADE	POTENZA POWER	CAPACITÀ TAGLIO OUTPUT PER HOUR	DIMENSIONI DIMENSIONS	PESO WEIGHT
300 mm	0,23 HP	200X240 mm	570X520X500	24 KG

SLV 300S - BC

BRACCIO A COLONNA
COLUMN ARM

SLV 300S - BS

BRACCIO SPECIALE
SPECIAL ARM

	COD
SLV 300S - BC	7100111300SV
SLV 300S - BS	7100111300SVS

Caratteristiche

Per grandi attività, pizzerie, ristoranti, grossi prosciutti cotti e crudi da 8-12 kg, tutti i tipi di salumi, e carni crude-formaggi.

Features

For large activities, pizzerias, restaurants, large cooked and raw hams of 8-12 kg, all types of meats, and raw meats-cheeses.



SLV 350S - BC | SLV 370S - BC



SLV 350S - BS | SLV 370S - BS

SLV 350S

LAMA BLADE	POTENZA POWER	CAPACITÀ TAGLIO OUTPUT PER HOUR	DIMENSIONI DIMENSIONS	PESO WEIGHT
350 mm	0,37 HP	250x290 mm	780x640x660	38 KG

SLV 350S - BC

BRACCIO A COLONNA
COLUMN ARM

SLV 350S - BS

BRACCIO SPECIALE
SPECIAL ARM

	COD
SLV 350S - BC	7100111350SV
SLV 350S - BS	7100111350SVS

SLV 370S

LAMA BLADE	POTENZA POWER	CAPACITÀ TAGLIO OUTPUT PER HOUR	DIMENSIONI DIMENSIONS	PESO WEIGHT
370 mm	0,37 HP	260x300 mm	780x640x660	39 KG

SLV 370S - BC

BRACCIO A COLONNA
COLUMN ARM

SLV 370S - BS

BRACCIO SPECIALE
SPECIAL ARM

	COD
SLV 370S - BC	7100111370SV
SLV 370S - BS	7100111370SVS

Preparazione
Carne





Cottura Cooking

Cottura

URI LINE

Piastra elettrica in vetroceramica

Glass ceramic electrical grill



PIASTRA VETROCERAMICA | CERAMIC GLASS GRILL

Caratteristiche

- Struttura in acciaio inox
- Piano in vetroceramica di elevato spessore ad alta resistenza termica
- Ampia superficie utile di lavoro
- Piano superiore bilanciata e regolabile
- Elevatissima velocità di riscaldamento (300° C in 3 min. 1/2)
- Regolazione della temperatura con termostato in acciaio inox fino a 300° C
- Interruttore on/off con spia luminosa
- Cassetto estraibile di raccolta grassi, lavabile in lavastoviglie
- Raschietto di pulizia
- Basso consumo energetico grazie all'efficiente sistema riscaldante e all'ottimo isolamento
- Disponibili nella versione CE

Features

- Stainless steel structure
- Thick glass ceramic plate for a higher heating resistance
- Large working surface
- Balanced upper plate with adjustable closing pressure
- Ultra high heating speed (300° C in 3 minutes and a half)
- Stainless steel thermostat to adjust the temperature up to max 300°C
- On/off switch with orange indicator light
- Removable crumb/drip tray washable in dishwasher
- Low Energy consumption thanks to the heating and insulation system
- Soft-touch ergonomic knob
- Available in the CE version



URI M

URI D

	URI M	URI D
DIMENSIONE PRODOTTO PRODUCT DIMENSIONS	410x480x210	640x480x210
PIANO COTTURA - COOKING SURFACE	280x380	280x585
ALIMENTAZIONE - POWER SUPPLY	230 V - 50 HZ	230 V - 50 HZ
POTENZA - MOTOR POWER	2,1 KW	3,2 KW
TEMPERATURA MAX - TEMPERATURE MAX	300°	300°
PESO - WEIGHT	13 KG	21,5 KG
DIMENSIONE IMBALLO - PACKING DIMENSIONS	500x500x270	730x500x290
COD.	7090111URIM	7090111URID

Fornite con piani lisci ma che su richiesta sono disponibili con piano superiore rigato
 Supplied with smooth floors but that on request are available with upper ribbed top

RIND LINE

Piastra a induzione

Induction grill



PIASTRA AD INDUZIONE | INDUCTION GRILL

Caratteristiche

- Struttura in acciaio inox • Timer con display a led (0-180 min)
- Piano in vetro nera
- Protezione elettronica per il surriscaldamento
- Doppia ventola di raffreddamento
- Pentole utilizzabili (acciaio/ferro smaltato con o senza rivestimento anti aderente, pentole in acciaio, pentolame in ghisa con o senza base smaltata, pentole in alluminio e anodizzazione molto resistente ma solo se hanno un fondo apposito per utilizzo su piastra a induzione)
- Pentole non utilizzabili (contenitori con fondo arrotondato o con piedini, contenitori con diametro inferiore a 12 cm e superiore a 26 cm, contenitori realizzati in: vetro, ceramica, terracotta, alluminio e rame a meno che queste pentole siano provviste di un fondo speciale per l'utilizzo con piano a induzione)
- Facile da pulire • Norme CE

Features

- Stainless steel structure
- Timer function 1-180 min
- Black glass plate
- Electronic protection for overheating
- Double cooling fan
- Easy to clean
- CE approved
- Proudly Made in Italy



RIND 2,5



RIND 3,5



RIND 2,7 EXP



RIND 3,5 EXP



	RIND 2,5	RIND 3,5	RIND 2,7 EXP	RIND 3,5 EXP
POTENZA - POWER	2,5 KW	3,5 KW	2,7 KW	3,5 KW
ALIMENTAZIONE POWER SUPPLY	1ph	1ph	1ph	1ph
PIANO UTILE PLATE DIMENSIONS	322X270	330x275	280x280	280x280
PESO NETTO NET WEIGHT	7,5 kg	11 kg	4 kg	5 kg
PESO LORDO GROSS WEIGHT	9 kg	12,5	4,5 kg	5,5 kg
DIMENSIONE PRODOTTO PRODUCT DIMENSIONS	320x440x115	340x460x135	323x370x105	330x425x105
DIMENSIONE IMBALLO PACKING DIMENSIONS	500x370x180	510x380x200	360x425x130	385x475x145
COD.	7090111RIND25	7090111RIND35	7090111RIND27E	7090111RIND35E

PS LINE

Piastra elettrica in ghisa
Cast iron electrical grill



Caratteristiche

Griglie elettriche a contatto con piastra in ghisa rigata appositamente trattata per facilitare la pulizia, autobilanciamento della piastra superiore, molle in acciaio, impugnatura in materiale termoisolante, termostato di regolazione con interruttore rotativo incorporato.

Features

Electric contact grills with cast iron grooved plate with special treatment for an easy cleaning, autobalanced upper plate with steel springs, heat-proof handles, adjustable thermostat with rotative switch built in.



PS 2010 RR



PS 2015 RR



PS 2020 RR



	PS 2010	PS 2015	PS 2020
DIMENSIONI DIMENSIONS	260x435x235	380x435x235	515x435x235
PIANO COTTURA COOKING SURFACE	250x255	355x255	500x255
ALIMENTAZIONE POWER SUPPLY	230	230	230
POTENZA POWER	1,55 KW	2,1 KW	3,0 KW
TEMPERATURA TEMPERATURE	300°	300°	300°
PESO WEIGHT	16 kg	22 kg	28 kg
DIMENSIONE IMBALLO PACKAGE DIMENSIONS	490x320x330	430x420x270	560x430x270

	COD
PS 2010 RR	7090111PS2010RR
PS 2010 LR	7090111PS2010LR
PS 2010 LL	7090111PS2010LL
PS 2015 RR	7090111PS2015RR
PS 2015 LR	7090111PS2015LR
PS 2015 LL	7090111PS2015LL
PS 2020 RR	7090111PS2020RR
PS 2020 LR	7090111PS2020LR
PS 2020 LL	7090111PS2020RL

RR 2 PIASTRE RIGATE - 2 STRIPED PLATES

LR 1 PIASTRA LISCIA INFERIORE E 1 PIASTRA RIGATA SUPERIORE
1 BOTTOM SMOOTH PLATE AND 1 HIGHER STRIPED PLATE

LL 2 PIASTRE LISCE - 2 SMOOTH PLATES

TBR LINE

Tostiera elettrica
Electrical toaster



Caratteristiche

- Corpo in acciaio inox
- Resistenze al quarzo più robuste
- Temporizzatore
- Griglia con manico a richiesta
- Pinze incluse

Features

- Stainless-steel body
- Thicker type quartz element
- Time switch
- Grid with handle on request
- Tongs included



TBR 3

TBR 33

TBR 4

	TBR 3	TBR 33	TBR 4
VOLT	230/50	230/50	230/50
POTENZA POWER	KW 2	KW 3	KW 2
DIMENSIONI INTERNE INSIDE DIMENSIONS	mm 320 x 230 x 80 h	mm 320 x 230 x 160 h	mm 540 x 340 x 100 h
DIMENSIONI ESTERNE OUTSIDE DIMENSIONS	mm 450 x 250 x 250 h	mm 450 x 250 x 360 h	mm 710 x 340 x 300 h
COD.	7090111TBR3	7090111TBR33	7090111TBR4

Cottura

GPL LINE

Griglia a pietra lavica a GAS

Lava stone GAS grill



Caratteristiche

Corpo in acciaio inox, adatta sia ad uso semi professionale che professionale, in dotazione kit ugelli per GPL G30 e gas naturale G20, griglia di cottura in tondini di acciaio inox Ø 6 mm, cassetto raccolta residui di cottura.

Features

Stainless-steel body, suitable for both semi-professional and professional use, supplied with nozzles for LP Gas G30 and natural gas G20, working surface made by stainless-steel rods Ø 6 mm, fat collection drawer.



GPL 1

GPL 2

	GPL1	GPL2
POTENZA - POWER	KW 9	KW 18
SUPERFICIE DI COTTURA - COOKING SURFACE	mm 532 x 352	mm 650 x 480
DIMENSIONI - DIMENSIONS	mm 525 x 390 x 363 h	mm 685 x 570 x 310 h
COD.	7090111GPL1	7090111GPL2

Cottura

TAFT / GAS LINE

Fry top elettrico e a GAS

Electrical and GAS fry top



TAFT

Caratteristiche

Corpo in acciaio inox, piano di cottura in acciaio liscio o rigato, termostato regolabile 0-300°C, cassetto raccolta residui di cottura. Fry top elettrico

Features

Stainless steel body, cooking surface in steel smooth or grooved, adjustable thermostate 0-300°C, fat collection drawer. Electrical fry top



TAFT4L



TAFT6L



TAFT8L

	SINGOLA PIASTRA LISCIA SINGLE SMOOTH PLATE		SINGOLA PIASTRA RIGATA SINGLE GROOVED PLATE		SINGOLA PIASTRA LISCIA SINGLE SMOOTH PLATE		SINGOLA PIASTRA RIGATA SINGLE GROOVED PLATE		DOPPIA PIASTRA LISCIA DOUBLE SMOOTH PLATE		PIASTRA 2/3 LISCIA - 1/3 RIGATA 2/3 SMOOTH PLATE - 1/3 GROOVED	
	TAFT4L	TAFT4R	TAFT6L	TAFT6R	TAFT6L	TAFT6R	TAFT8L	TAFT8R	TAFT8L	TAFT8R	TAFT8L	TAFT8R
VOLTAGGIO - VOLTAGE	230 V				400 V				400 V			
POTENZA - POWER	3 kW				6 kW				9 kW			
PIANO COTTURA COOKING SURFACE	mm 395x400				mm 595x400				mm 835x400			
DIMENSIONI ESTERNE OUTSIDE DIMENSIONS	mm 400x500x200 h				mm 600x500x200 h				mm 840x500x200 h			
PESO - WEIGHT	22 KG				35 KG				55 KG			
COD.	7140101TAFT4L	7140101TAFT4R	7140101TAFT6L	7140101TAFT6R	7140101TAFT6L	7140101TAFT6R	7140101TAFT8L	7140101TAFT8R	7140101TAFT8L	7140101TAFT8R	7140101TAFT8L	7140101TAFT8R

GAS

Caratteristiche

Corpo in acciaio inox, piano di cottura in acciaio liscio o rigato, manopola regolazione bruciatori, accensione con piezo elettrico, cassetto raccolta residui di cottura. Fry top a gas

Features

Stainless steel body, cooking surface in steel smooth or grooved, knob for burners adjustment, piezo electric ignition, fat collection drawer. Gas fry top



GAS35L



GAS60L

	SINGOLA PIASTRA LISCIA SINGLE SMOOTH PLATE		SINGOLA PIASTRA RIGATA SINGLE GROOVED PLATE		SINGOLA PIASTRA LISCIA SINGLE SMOOTH PLATE		SINGOLA PIASTRA RIGATA SINGLE GROOVED PLATE	
	GAS35L	GAS35R	GAS60L	GAS60R	GAS60L	GAS60R	GAS60L	GAS60R
BRUCIATORI - BURNERS	1		1		2		2	
POTENZA - POWER	4 kW		4 kW		8 kW		8 kW	
PIANO COTTURA COOKING SURFACE	mm 325x500		mm 325x500		mm 600x400		mm 600x400	
DIMENSIONI ESTERNE OUTSIDE DIMENSIONS	mm 330x550x200 h		mm 330x550x200 h		mm 600x450x200 h		mm 600x450x200 h	
PESO - WEIGHT	23 kg		23 kg		36 kg		36 kg	
COD.	7140101GAS35L	7140101GAS35R	7140101GAS60L	7140101GAS60R	7140101GAS60L	7140101GAS60R	7140101GAS60L	7140101GAS60R

CRE LINE

Crepiera elettrica

Electrical pancakes maker



Caratteristiche

Crepier con piastra di cottura diametro 350mm in ghisa speciale trattata con smalto antigraffio e antiacido adatto al contatto con alimenti. Disponibile nella versione singola o doppia.

Features

Pancake maker with hot plate diam. 350mm made of special treated scratch resistant cast iron. Available single and double.



CRE 1

CRE 2

	CRE 1	CRE 2
DIMENSIONI - DIMENSIONS	380x380x190h	760x380x190h
DIAMETRO - DIAMETER	350mm	2x350mm
VOLT	230V	400V 3N
POTENZA - POWER	2,4 KW	4,8 KW
PESO - WEIGHT	16Kg	30Kg
COD.	7090111CRE1	7090111CRE2

Cottura

FTR LINE

Friggitrice elettrica

Electrical fryer



Caratteristiche

Corpo in acciaio inox con maniglie e coperchio, 1 o 2 vasche estraibili in acciaio inox per una migliore igiene, testata estraibile, micro interruttore di sicurezza termostato di sicurezza e termostato di regolazione temperatura, interruttore on/off.

Dotazioni Standard

Corpo in acciaio inox con maniglie e coperchio
Micro-interruttore di sicurezza
Termostato di sicurezza
Interruttore ON-OFF
Termostato per regolazione della temperatura

Features

Stainless steel body with handles and lid, stainless-steel 1 or 2 removable bowls for easy cleaning, removable head, safety micro switch, safety thermostat and thermostat for temperature adjustment, on/off switch.

Standard equipment

Stainless-steel construction with handles and lid
Safety micro-switch
Safety thermostat
ON-OFF switch
Thermostat for temperature adjustment



FTR 4



FTR 44



FTR 4S

	FTR 4	FTR 44	FTR 4S
VOLUME DELLA VASCA BOWL VOLUME	Lt. 7	Lt. 7+7	Lt. 7
CAPACITÀ LAVORATIVA WORKING CAPACITY	Lt. 4	Lt. 4 + 4	Lt. 3,5
VOLT	230 V / 50 monofase	230 V / 50 monofase	230 V / 50 monofase
POTENZA - POWER	kW 2	KW 4	KW 2,5
DIMENSIONI - DIMENSIONS	mm 190 x 430 x 290 h	mm 380 x 430 x 290 h	mm 260 x 390 x 190 h
DIMENSIONI CESTELLO - BASKET CAPACITY	140 x 250 x 100h	2 x 140 x 250 x 100h	220 x 250 x 50h
COD.	7080111FTR4	7080111FTR44	7080111FTR4S



FTR 8



FTR 88



FTR 10

	FTR 8	FTR 88	FTR 10
VOLUME DELLA VASCA BOWL VOLUME	Lt. 11	Lt. 11 + 11	Lt. 15
CAPACITÀ LAVORATIVA WORKING CAPACITY	Lt. 6	Lt. 6 + 6	Lt. 10
VOLT	230 V / 50 monofase	230 V / 50 monofase	400 V trifase
POTENZA - POWER	KW 3,25	KW 6	KW 6
DIMENSIONI - DIMENSIONS	mm 280 x 430 x 210 h	mm 560 x 430 x 210 h	mm 370 x 430 x 210h
DIMENSIONI CESTELLO - BASKET CAPACITY	220 x 250 x 100h	2X 220 x 250 x 100h	320 x 250 x 120h
COD.	7080111FTR8	7080111FTR88	7080111FTR10



FTR 8R



FTR 88R



FTR 18R

	FTR 8R	FTR 88R	FTR 18R
VOLUME DELLA VASCA BOWL VOLUME	Lt. 13	Lt. 13 + 13	Lt. 24
CAPACITÀ LAVORATIVA WORKING CAPACITY	Lt. 8	Lt. 8 + 8	Lt. 18
VOLT	230 V / 50 monofase	230 V / 50 monofase	400 V trifase
POTENZA - POWER	KW 3,25	KW 3,25 + 3,25	KW 9
DIMENSIONI - DIMENSIONS	mm 280 x 430 x 250 h	mm 560 x 430 x 250 h	mm 600 x 620 x 500h
DIMENSIONI CESTELLO - BASKET CAPACITY	220 x 250 x 100h	2X 220 x 250 x 100h	460 x 320 x 120h
COD.	7080111FTR8R	7080111FTR88R	7080111FTR18





Refrigerazione Refrigeration

ICE LINE

Armadio refrigerato ventilato

Refrigerated ventilated cabinet



Caratteristiche

- Struttura interna ed esterna in acciaio inox
- Refrigerazione ventilata
- Sbrinamento automatico
- Termostato digitale
- Porta reversibile
- Maniglia in acciaio inox
- Chiave e luce di serie
- 3/6 Griglie e 3/6 coppie di guide di serie (650bt-tn/1410bt-tn)

Features

- Internal and external structure in stainless steel
- Ventilated refrigeration
- Automatic defrost
- Digital thermostat
- Reversible door
- Stainless steel handle
- Key and light included
- 3/6 Grills and 3/6 pairs of standard guides (650bt-tn / 1410bt-tn)

**ICE GN650TN - ICE GN650BT****ICE GN1410TN - ICE GN1410BT**

	ICE GN650TN	ICE GN650BT	ICE GN1410TN	ICE GN1410BT
ALIMENTAZIONE - POWER SUPPLY	230 V - 50 HZ	230 V - 50 HZ	230 V - 50 HZ	230 V - 50 HZ
POTENZA - POWER	0,3 KW - 0,4 HP	0,7 KW - 0,95 HP	0,65 KW - 0,85 HP	0,95 KW - 1,25 HP
TEMPERATURA TEMPERATURE	-2°C +8°C	-18°C -22°C	-2°C -8°C	-18°C -22°C
CAPACITÀ - CAPACITY	650 LT	650 LT	1333 LT	1333 LT
CLASSE ENERGETICA ENERGY CLASS	D	E	D	E
CLASSE CLIMATICA CLIMATE CLASS	4	4	4	4
PESO NETTO NET WEIGHT	134 KG	138 KG	198 KG	208 KG
PESO LORDO GROSS WEIGHT	143 KG	147 KG	213 KG	226 KG
DIMENSIONI INTERNE INTERNAL SIZE	mm 624x700x1400	mm 624x700x1400	mm 1360x700x1400	mm 1360x700x1400
DIMENSIONE PRODOTTO ITEM SIZE	mm 740x830x2010	mm 740x830x2010	mm 1480x830x2010	mm 1480x830x2010
DIMENSIONE IMBALLO PACKAGING SIZE	mm 770x860x2070	mm 770x860x2070	mm 1510x860x2070	mm 1510x860x2070
COD.	716042165TI	716042165BI	716042114TI	716042114BI

TVP LINE

Banco pizza refrigerato ventilato

Refrigerated ventilated pizza counter



Caratteristiche

- Struttura interna ed esterna in acciaio inox
- Refrigerazione ventilata
- Sbrinamento automatico
- Termostato digitale
- Porta reversibile
- Maniglia in acciaio inox
- Chiave e luce di serie
- Top in granito h20 cm
- 1 Griglia 60x40cm

Features

- Internal and external structure in stainless steel
- Ventilated refrigeration
- Automatic defrost
- Digital thermostat
- Reversible door
- Stainless steel handle
- Key and light included
- Granite top h20 cm
- N.1 60x40cm shelf



TVP PZ2600TN 2SP



TVP PZ1610TN 1SP+7CA



TVP PZ3600TN 3SP



TVP PZ2610TN 2SP+7CA

	TVP PZ2600TN 2SP	TVP PZ1610TN 1SP+7CA	TVP PZ3600TN 3SP	TVP PZ2610TN 2SP+7CA
ALIMENTAZIONE - POWER SUPPLY	230 V - 50 HZ	230 V - 50 HZ	230 V - 50 HZ	230 V - 50 HZ
POTENZA - POWER	0,3 KW - 0,4 HP	0,3 KW - 0,4 HP	0,35 KW - 0,47 HP	0,3 KW - 0,4 HP
TEMPERATURA - TEMPERATURE	-2°C +8°C	-2°C +8°C	-2°C +8°C	-2°C +8°C
TIPO REFRIGERANTE - COOLING TYPE	R290	R290	R290	R290
CLASSE ENERGETICA - ENERGY CLASS	C	C	C	C
CLASSE CLIMATICA - CLIMATE CLASS	4	4	4	4
CAPACITÀ - CAPACITY	390 LT	390 LT	580 LT	580 LT
PESO NETTO - NET WEIGHT	260 KG	260 KG	312 KG	312 KG
PESO LORDO - GROSS WEIGHT	293 KG	293 KG	354 KG	354 KG
DIMENSIONI INTERNE - INSIDE DIMENSIONS	mm 1052x630x589	mm 1052x630x589	mm 1562x630x589	mm 1052x630x589
DIMENSIONE PRODOTTO - ITEM SIZE	mm 1510x800x1000	mm 1510x800x1000	mm 2025x800x1000	mm 2025x800x1000
DIMENSIONE IMBALLO - PACKAGING SIZE	mm 1540x830x1020	mm 1540x830x1020	mm 2060x830x1020	mm 2060x830x1020
COD.	716012126TI	716013116TI	716012136TI	716013126TI

VRX LINE

Vetrinetta refrigerata per pizzeria

Refrigerated topping unit for pizzeria



Caratteristiche

- Struttura interna ed esterna realizzata interamente in acciaio inox
- Refrigerazione statica
- Gruppo incorporato
- Termostato digitale per il controllo della temperatura
- Vetri di protezione inclusi
- Idonee a contenere bacinelle gastronomiche in acciaio inox o in policarbonato con profondità massima di 150mm (bacinelle e coperchi esclusi)
- Norme CE

Features

- Internal and external structure made entirely of stainless steel
- Static refrigeration
- Built-in group
- Digital thermostat for temperature control
- Protection glasses included
- Suitable for containing gastronomic containers in stainless steel or polycarbonate with a maximum depth of 150mm (basins and lids excluded)
- CE standards



VRX

	VRX 12033	VRX 14033	VRX 14038	VRX 15033	VRX 15038	VRX 18033	VRX 20033	VRX 20038
ALIMENTAZIONE POWER SUPPLY	230 V - 50 HZ	230 V - 50 HZ	230 V - 50 HZ	230 V - 50 HZ	230 V - 50 HZ	230 V - 50 HZ	230 V - 50 HZ	230 V - 50 HZ
POTENZA - POWER	150W	150W	150W	150W	150W	150W	150W	150W
TEMPERATURA TEMPERATURE	0°C +10°C	0°C +10°C	0°C +10°C	0°C +10°C	0°C +10°C	0°C +10°C	0°C +10°C	0°C +10°C
TIPO REFRIGERANTE COOLING TYPE	R134A - R600A	R134A - R600A	R134A - R600A	R134A - R600A	R134A - R600A	R134A - R600A	R134A - R600A	R134A - R600A
PESO NETTO - NET WEIGHT	50 KG	55 KG	58 KG	58 KG	61 KG	65 KG	70 KG	73 KG
PESO LORDO - GROSS WEIGHT	55 KG	60 KG	63 KG	63 KG	66 KG	70 KG	75 KG	78 KG
DIMENSIONE PRODOTTO ITEM SIZE	mm 1200x335x435	mm 1400x355x435	mm 1400x395x435	mm 1500x335x435	mm 1500x395x435	mm 1800x355x435	mm 2000x355x435	mm 2000x396x435
DIMENSIONE IMBALLO PACKAGING SIZE	mm 1270x380x410	mm 1470x380x410	mm 1470x460x410	mm 1570x380x410	mm 1570x460x410	mm 1870x380x410	mm 2070x380x410	mm 2070x460x410
COD.	716032212TI	716032214TI	716032114TI	716032215TI	716032115TI	716032218TI	716032220TI	716032120TI

BACINELLE GN E COPERCHI - GN PANS AND COVERS

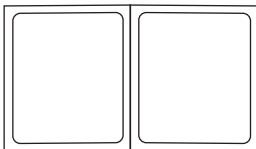

GN 1/2

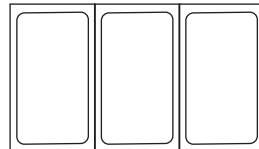

GN 1/3

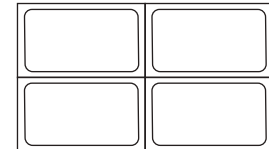

GN 1/4

SERIES 380

MAX 150H mm

SERIES 330

MAX 150H mm

BACINELLE GN / GN PANS

	GN 1/2	GN 1/3	GN 1/4
DIMENSIONE PRODOTTO ITEM SIZE	mm 325x265	mm 325x176	mm 162x265
COD.	7210100105	7210100103	7210100104

COPERCHIO BACINELLE GN / GN COVERS PANS

	GN 1/2	GN 1/3	GN 1/4
DIMENSIONE PRODOTTO ITEM SIZE	mm 325x265	mm 325x176	mm 162x265
COD.	7210100108	7210100106	7210100107

BRI LINE

Banco refrigerato ventilato
Refrigerated ventilated counter



Caratteristiche

- Struttura interna ed esterna in acciaio inox
- Refrigerazione ventilata
- Sbrinatorio automatico
- Termostato digitale
- Maniglia in acciaio inox

Features

- Internal and external structure in stainless steel
- Ventilated refrigeration
- Automatic defrost
- Digital thermostat
- Stainless steel handle

* CON ALZATINA - WITH SPLASHBACK



BRI GN2200 TN

**BRI GN2100 TN**

BRI GN3200 TN

**BRI GN3100 TN**

BRI GN4200 TN

**BRI GN4100 TN**

	BRI GN2100 TN	BRI GN2200 TN *	BRI GN3100 TN	BRI GN3200 TN *	BRI GN4100 TN	BRI GN4200 TN *
DIMENSIONI - DIMENSIONS	mm 1360x700x850	mm 1360x700x950	mm 1795x700x850	mm 1795x700x950	mm 2230x700x850	mm 2230x700x950
CAPACITÀ - CAPACITY	282 LT	282 LT	417 LT	417 LT	553 LT	553 LT
SISTEMA DI RAFFREDDAMENTO COOLING SYSTEM	VENTILATO - VENTILATED	VENTILATO - VENTILATED	VENTILATO - VENTILATED	VENTILATO - VENTILATED	VENTILATO - VENTILATED	VENTILATO - VENTILATED
TEMPERATURA - TEMPERATURE	-2°C +10°C	-2°C +10°C	-2°C +10°C	-2°C +10°C	-2°C +10°C	-2°C +10°C
CLASSE ENERGETICA - ENERGY CLASS	C	C	C	C	C	C
CLASSE CLIMATICA - CLIMATE CLASS	4	4	4	4	4	4
PORTA - DOOR	2	2	3	3	4	4
PESO NETTO - NET WEIGHT	98 KG	98 KG	134 KG	134 KG	153 KG	153 KG
PESO LORDO - GROSS WEIGHT	113 KG	113 KG	152 KG	152 KG	173 KG	173 KG
COD.	716022121TI	716022122TI	716022131TI	716022132TI	716022141TI	716022142TI

**OPTIONAL 2 Cassetti - 2 Drawers****OPTIONAL**

- Set di 4 Ruote - 4 Wheels
- Set di 6 Ruote - 6 Wheels
- Set di due Cassetti - Set of two Drawers

COD. 716000004I
 COD. 716000006I
 COD. 716022000TI

BLAST LINE

Abbattitore di temperatura
Blast chiller



Caratteristiche

- Refrigerazione ventilata con agitatore d'aria
- Interno ed esterno in acciaio inossidabile, con esclusione del fondo esterno in Acciaio Galvanizzato
- Angoli interni arrotondati
- Isolamento in poliuretano senza CFC, iniettato ad alta pressione
- Spessore dell'isolamento 60 mm
- Porta con chiusura automatica e guarnizione magnetica
- Dotato di sonda al cuore
- Versione a Pannello frontale con scheda di controllo elettronica con sonda camera e sonda spillone al cuore
- Versione a Pannello Touch screen con display digitale (programmi di abbattimento positivo e negativo, temperatura di abbattimento, temperatura al cuore, tempi di abbattimento, conservazione)
- Unità refrigerante con griglia frontale apribile, di facile accesso per pulizia standard e manutenzione
- Evaporatore con trattamento anticorrosivo in cataforesi
- Sbrinamento a porta aperta, senza l'utilizzo di resistenze o gas caldo
- Vaschetta di contenimento acqua di condensa estraibile, in plastica
- Cicli impostabili con sonda al cuore +3°C e -18°C.
A richiesta fino a -40°C
- Kit di nr. 4 piedini in acciaio inox regolabili in altezza (60/80 H mm)
- Adatto a contenere 5 o 10 teglie GN 1/1 o 600x400 mm
- Teglie non incluse

Features

- Ventilated cooling with air shaker
- Inside and outside made of Stainless Steel, except for the external bottom made of Galvanized Steel
- Internal rounded corners
- Insulation in CFC free polyurethane high pressure injected
- Insulation thickness 60 mm
- Self-closing door with magnetic gaskets
- The core probe is included
- Version with Electronic front control panel with room probe and temperature core probe
- Version with touchscreen control panel with digital display (positive blast chilling, negative shock freezing, blast chilling temperature, core probe temperature, blast chilling time, conservation)
- Condensing unit with openable front grid for easy maintenance
- Defrosting with open door, without the use of resistors or hot gas
- Evaporator with cathaphoresis anticorrosive treatment
- Removable plastic bottom tray for condensate water collection
- Cycles can be set with a core probe +3°C and -18°C.
On request down to -40°C
- Kit of no. 4 adjustable stainless steel feet (height: 60/90 mm)
- Suitable for 5 or 10 trays GN 1/1 or 600x400 mm
- Trays not included



BLAST AD5



BLAST AD10



BLAST AT5



BLAST AT10

	BLAST AD5	BLAST AD10	BLAST AT5	BLAST AT10
DIMENSIONI mm. - DIMENSIONS mm.	750 x 750 x 890/910	750 x 750 x 1310/1330	750 x 750 x 890/910	750 x 750 x 1310/1330
DIMENSIONI INTERNE mm. - INTERNAL DIMENSIONS mm.	610 x 430 x 390	610 x 430 x 760	610 x 430 x 390	610 x 430 x 760
CAPACITÀ TEGLIE - TRAYS CAPACITY	5-GN 1/1 / 5-600x400	10-GN 1/1 / 10-600x400	5-GN 1/1 / 5-600x400	10-GN 1/1 / 10-600x400
CAPACITÀ - CAPACITY	100 LT	190 LT	100 LT	190 LT
SPAZIO TRA GRIGLIE mm. - SPACE BETWEEN GRIDS mm.	70	70	70	70
RESA ABBATTIMENTO +3°C - BLAST CHILLER YIELD +3°C	23 KG	25 KG	23 KG	25 KG
RESA SURGELAZIONE -18°C - FREEZING YIELD -18°C	12 KG	15 KG	12 KG	15 KG
ASSORBIMENTO AVVIAMENTO - STARTING ELECTRICAL INPUT	1300 W / 7,5 A	1300 W / 7,8 A	1300 W / 7,5 A	1300 W / 7,8 A
ASSORBIMENTO A REGIME - STEADY STATE ELECTRICAL INPUT	600 W / 4,7 A	800 W / 5,4 A	600 W / 4,7 A	800 W / 5,4 A
POTENZA FRIGORIFERA VERSIONE SENZA GRUPPO T.EVAP. -30°C COOLING CAPACITY FOR VERSION WITHOUT CONDENSING UNIT EVAP.T. -30°C	880 W	950 W	880 W	950 W
GAS REFRIGERANTE - COOLING GAS	R452A - R455A - R290 (a richiesta)	R452A - R455A - R290 (a richiesta)	R452A - R455A - R290 (a richiesta)	R452A - R455A - R290 (a richiesta)
TEMPERATURA - TEMPERATURE	+3°C / -18°C	+3°C / -18°C	+3°C / -18°C	+3°C / -18°C
CLASSE CLIMATICA - CLIMATE CLASS	4 - Temperatura + 30°C / Umidità relativa 60%	4 - Temperatura + 30°C / Umidità relativa 60%	4 - Temperatura + 30°C / Umidità relativa 60%	4 - Temperatura + 30°C / Umidità relativa 60%
ALIMENTAZIONE - POWER SUPPLY	220 / 240 V - 1P - 50Hz (60 Hz A richiesta)	220 / 240 V - 1P - 50Hz (60 Hz A richiesta)	220 / 240 V - 1P - 50Hz (60 Hz A richiesta)	220 / 240 V - 1P - 50Hz (60 Hz A richiesta)
PESO NETTO - NET WEIGHT	92,5 KG	111 KG	92,5 KG	111 KG
PESO LORDO - GROSS WEIGHT	97,5 KG	118 KG	97,5 KG	118 KG
COD.	71605005AD	71605010AD	71605005AT	71605010AT

Resto Italia® by TecnoA - Tutti i diritti riservati - "Resto Italia" è un marchio registrato

Tecno A Srl si riserva il diritto di modificare senza preavviso le caratteristiche delle apparecchiature presentate in questa pubblicazione

Resto Italia® by TecnoA - All rights reserved - "Resto Italia" is a registered trademark

Tecno A Srl reserves the right to change without prior notice any feature of the machines shown in this publishing

Concept & Graphic Design:

binario01.com



SEDE LEGALE

Via del Lavoro 4 - Loc. Canavaccio 61029 Urbino PU Italy

SEDE OPERATIVA

Via dell'Industria 23 - Loc. Canavaccio 61029 Urbino PU Italy

T. +39 0722 354048 | F. +39 0722 354049

info@restoitalia.com

restoitalia.com